



Driveover PitStop

Portable Grain Belt Conveyor Operator's Manual

This manual applies to:

1800 Series

2400 Series

Gas, Electric, and Hydraulic Drives

Original Instructions



Read this manual before using product. Failure to follow instructions and safety precautions can result in serious injury, death, or property damage. Keep manual for future reference.

Part Number: P1511025 R2

Revised: May 2018



CONTENTS

- 1. Introduction 5**
 - 1.1. Serial Number Location 5
 - 1.2. Intended Use 5
 - 1.2.1 Misuse 6
- 2. Safety..... 7**
 - 2.1. Safety Alert Symbol and Signal Words..... 7
 - 2.2. General Product Safety 7
 - 2.3. Moving Conveyor Belt Safety..... 8
 - 2.4. Rotating Parts Safety..... 8
 - 2.5. Work Area Safety 8
 - 2.6. Guards Safety 9
 - 2.7. Towing the Conveyor 10
 - 2.8. Drives and Lockout Safety..... 10
 - 2.8.1 Electric Motor Safety..... 11
 - 2.8.2 Hydraulic Power Safety 12
 - 2.9. Tire Safety..... 13
 - 2.10. Personal Protective Equipment..... 13
 - 2.11. Safety Equipment 14
 - 2.12. Safety Decals 14
 - 2.12.1 Decal Installation/Replacement..... 14
 - 2.12.2 Safety Decal Locations and Details 15
- 3. Features..... 20**
- 4. Transport..... 21**
 - 4.1. Transport Safety 21
 - 4.2. Transport Preparation 21
 - 4.3. Transport Procedure 22
- 5. Placement 24**
 - 5.1. Placement Safety..... 24
 - 5.2. Positioning the Pitstop 24
 - 5.3. Truck Positioning 24
 - 5.4. Lift Valve 25
 - 5.5. Collapsible Hopper Control 25
- 6. Operation 26**
 - 6.1. Operation Safety 26
 - 6.2. Start-up and Break-in 26
 - 6.3. Operation - Electric Motor Models..... 27
 - 6.4. Operation - Hydraulic Motor Models 27
 - 6.5. Conveyor Belt Speed 27
 - 6.6. Emergency Shutdown 28
 - 6.7. Restarting with a Full Tube 28
 - 6.8. Shutdown 28
 - 6.9. Clean Out..... 28
 - 6.10. Conveying Fertilizer..... 29
 - 6.11. Storage..... 30
- 7. Maintenance 31**

7.1. Maintenance Safety	31
7.2. Maintenance Schedule	31
7.3. Visually Inspect the Equipment.....	32
7.4. Lubricate the Equipment.....	32
7.5. Oil the Chain Coupler	33
7.6. Inspect Hydraulic Hoses and Fittings	33
7.7. Inspect the Hopper Flashing	34
7.8. Check the Hydraulic Oil Level.....	34
7.9. Check the Roller Bearings	34
7.10. Check the Roller Lagging	34
7.11. Tension the Conveyor Belt	35
7.12. Align the Conveyor Belt.....	36
7.12.1 Adjust the Rollers	37
7.13. Inspect Belt Lacing.....	38
7.14. Replace the Belt Lacing	38
7.15. Replace the Conveyor Belt	39
7.16. Clean and Wash the Equipment	40
7.17. Tension the Drive Belts	40
7.18. Align the Drive Belts.....	41
7.19. Replace the Drive Belts	41
7.20. Repack the Wheel Bearings with Grease.....	42
8. Assembly	43
8.1. Required Tools.....	43
8.2. Hydraulic Drive Kit.....	44
8.3. Electric Top Drive Assembly.....	46
8.4. Electric Wet Kit	49
9. Troubleshooting.....	52
10. Specifications	54
11. Batco Limited Warranty	55

1. Introduction

Thank you for purchasing a Batco Portable Grain Belt Conveyor. This equipment will allow safe and efficient operation when you read and follow all of the instructions contained in this manual. With proper care, your conveyor will provide you with many years of trouble-free operation.

Keep this manual handy for frequent reference and to review with new personnel. A sign-off form is provided on the inside front cover for your convenience. If any information in this manual is not understood or if you need additional information, please contact your local distributor or dealer for assistance.

This manual should be regarded as part of the equipment. Suppliers of both new and second-hand equipment are advised to retain documentary evidence that this manual was provided with the equipment.

1.1. Serial Number Location

Always give your dealer the serial number on your conveyor (shown below) when ordering parts or requesting service or other information. Please record this information in the table below for easy reference.

Model Number	
Serial Number	
Date Received	

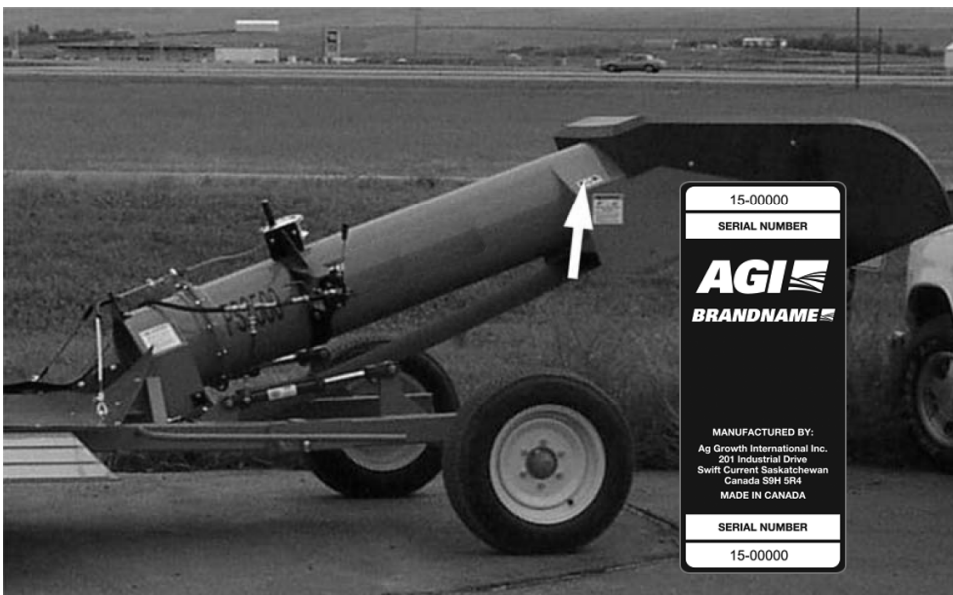

1.2. Intended Use

The conveyor is designed solely for use in the intended agricultural use as listed below. Use in any other way is considered as contrary to the intended use. Compliance with and strict adherence to the conditions of operation and maintenance as specified by the manufacturer, also constitute essential elements of the intended use.



The conveyor should be operated, maintained, serviced, and repaired only by persons who are familiar with its particular characteristics and who are acquainted with the relevant safety procedures.

Accident prevention regulations and all other generally recognized regulations on occupational health and safety must be observed at all times.

Any modifications made to the conveyor may relieve the manufacturer of liability for any resulting damage or injury.

Intended use for the conveyor:

- Handling grain, pulse crops, treated seeds, or other similar materials.
- Handling fertilizer when strict operation and cleanout procedures are followed as noted in Operation section.

Use in any other way is considered as contrary to the intended use and is not covered by the warranty.

1.2.1 Misuse

Do not use the conveyor for/with:

- transferring material other than dry, free-flowing food-grains.
- conveying canola, or any other oilseeds

2. Safety

2.1. Safety Alert Symbol and Signal Words





This safety alert symbol indicates important safety messages in this manual. When you see this symbol, be alert to the possibility of injury or death, carefully read the message that follows, and inform others.

Signal Words: Note the use of the signal words **DANGER**, **WARNING**, **CAUTION**, and **NOTICE** with the safety messages. The appropriate signal word for each message has been selected using the definitions below as a guideline.

 **DANGER** Indicates an imminently hazardous situation that, if not avoided, will result in serious injury or death.

 **WARNING** Indicates a hazardous situation that, if not avoided, could result in serious injury or death.

 **CAUTION** Indicates a hazardous situation that, if not avoided, may result in minor or moderate injury.

 **NOTICE** Indicates a potentially hazardous situation that, if not avoided, may result in property damage.

2.2. General Product Safety

YOU are responsible for the **SAFE** use and maintenance of your conveyor. **YOU** must ensure that you and anyone else who is going to work around the conveyor understands all procedures and related **SAFETY** information contained in this manual.

Remember, **YOU** are the key to safety. Good safety practices not only protect you, but also the people around you. Make these practices a working part of your safety program. All accidents can be avoided.

- It is the conveyor owner, operator, and maintenance personnel's responsibility to read and understand **ALL** safety instructions, safety decals, and manuals and follow them when assembling, operating, or maintaining the equipment.
- Owners must give instructions and review the information initially and annually with all personnel before allowing them to operate the conveyor. Untrained users/operators expose themselves and bystanders to possible serious injury or death.
- The conveyor is not intended to be used by children.
- Use the conveyor for its intended purposes only.
- Do not modify the conveyor in any way without written permission from the manufacturer. Unauthorized modification may impair the function and/or safety, and could affect the life of the conveyor. Any unauthorized modification of the conveyor will void the warranty.



2.3. Moving Conveyor Belt Safety

WARNING

- DO NOT step on or touch moving conveyor belt.
- Shut off and lock out power to adjust, service, or clean.



2.4. Rotating Parts Safety

WARNING

- Keep body, hair, and clothing away from rotating pulleys, belts, chains, and sprockets.
- Do not operate with any guard removed or modified. Keep guards in good working order.
- Shut off and remove key or lock out power source before inspecting or servicing machine.



2.5. Work Area Safety

- Have another trained person nearby who can shut down the conveyor in case of accident.
- The work area should be kept clear of bystanders.
- Keep the work area clean and free of debris.

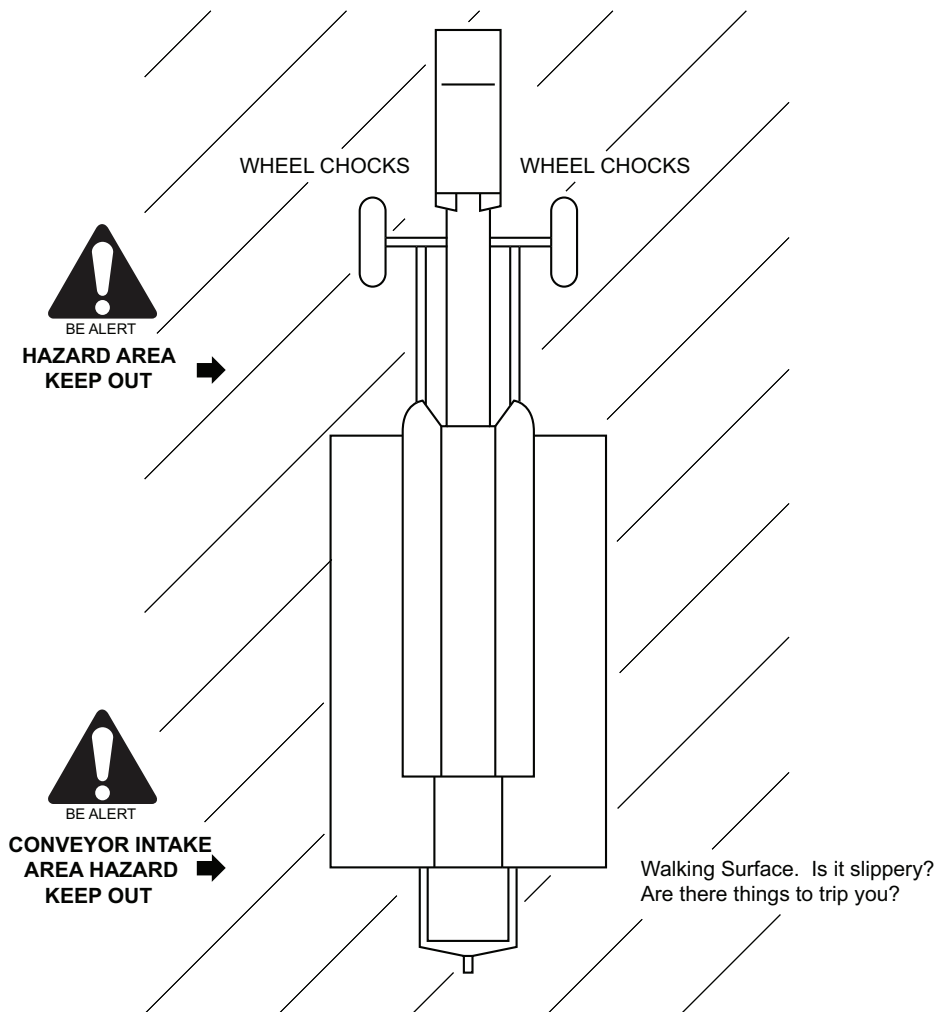
Figure 1. Pitstop Work Area

2.6. Guards Safety

- WARNING**
- Keep guards in place and do not operate unless all guards are in place.
 - Do not walk on, step on, or damage guards.
 - Lock out power before removing a guard.
 - Ensure all guards are replaced after performing maintenance.

2.7. Towing the Conveyor

WARNING

- Check with local authorities regarding transport on public roads. Obey all applicable laws and regulations.
- Always travel at a safe speed, never exceeding 20 mph (32 km/h).
- Reduce speed on rough surfaces.
- Do not transport on slopes greater than 20°.
- Use caution when turning corners or meeting traffic.
- Make sure the SMV (slow moving vehicle) emblem and all the lights and reflectors that are required by local authorities are in place, are clean, and can be seen by all over-taking and oncoming traffic.
- Always use hazard-warning flashers on tractor/towing vehicle when transporting unless prohibited by law.
- Do not allow riders on the conveyor or towing vehicle during transport.
- Attach to towing vehicle with an appropriate pin and retainer. Always attach safety chain(s).
- Place the conveyor in the transport position before moving on roads.

2.8. Drives and Lockout Safety

Inspect the power source(s) before using and know how to shut down in an emergency. Whenever you service or adjust your equipment, make sure you shut down the power source and unplug or remove the key (as applicable) to prevent inadvertent start-up and hazardous energy release. Know the procedure(s) that applies to your equipment from the following power source(s). Ensure that all personnel are clear before turning on power to equipment.

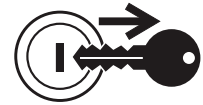

2.8.1 Electric Motor Safety

WARNING Power Source

- Electric motors and controls shall be installed and serviced by a qualified electrician and must meet all local codes and standards.
- A magnetic starter should be used to protect your motor.
- You must have a manual reset button.
- Reset and motor starting controls must be located so that the operator has full view of the entire operation.
- Locate main power disconnect switch within reach from ground level to permit ready access in case of an emergency.
- Motor must be properly grounded.
- Guards must be in place and secure.
- Ensure electrical wiring and cords remain in good condition; replace if necessary.
- Use a totally enclosed electric motor if operating in extremely dusty conditions.

Lockout

- The main power disconnect switch should be in the locked position during shutdown or whenever maintenance is performed.
- If reset is required, disconnect all power **before** resetting motor.

SERVICE DISCONNECT

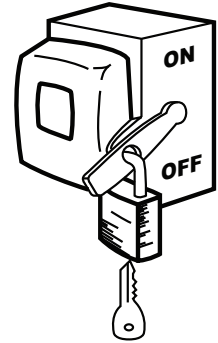

2.8.2 Hydraulic Power Safety

WARNING Power Source

- Refer to the rules and regulations applicable to the power source operating your hydraulic drive.
- Do not connect or disconnect hydraulic lines while system is under pressure.
- Keep all hydraulic lines away from moving parts and pinch points.
- Escaping hydraulic fluid under pressure will cause serious injury if it penetrates the skin surface (serious infection or toxic reaction can develop). See a doctor immediately if injured.
- Use metal or wood as a backstop when searching for hydraulic leaks and wear proper hand and eye protection.
- Check all hydraulic components are tight and in good condition. Replace any worn, cut, abraded, flattened, or crimped hoses.
- Clean the connections before connecting to equipment.
- Do not attempt any makeshift repairs to the hydraulic fittings or hoses with tape, clamps, or adhesive. The hydraulic system operates under extremely high pressure; such repairs will fail suddenly and create a hazardous and unsafe condition.

Lockout

- Always place all hydraulic controls in neutral and relieve system pressure before disconnecting or working on hydraulic system.



2.9. Tire Safety

WARNING Failure to follow proper procedures when mounting a tire on a wheel or rim can produce an explosion that may result in serious injury or death.



- DO NOT attempt to mount a tire unless you have the proper equipment and experience to do the job.
- Have a qualified tire dealer or repair service perform required tire maintenance.
- When replacing worn tires, make sure they meet the original tire specifications. Never undersize the replacement tire.
- DO NOT weld to the tire rim with the tire mounted on the rim. This action may cause an explosion which could result in serious injury or death.
- Inflate tires to the manufacturer's recommended pressure.
- Tires should not be operated at speeds higher than their rated speed.
- Keep wheel lug nuts tightened to manufacturer's recommendations.
- Never reinflate a tire that has been run flat or seriously under-inflated without removing the tire from the wheel. Have the tire and wheel closely inspected for damage before remounting.

2.10. Personal Protective Equipment

The following Personal Protective Equipment (PPE) should be worn when operating or maintaining the equipment.

Safety Glasses

- Wear safety glasses at all times to protect eyes from debris.



Coveralls

- Wear coveralls to protect skin.



Hard Hat

- Wear a hard hat to help protect your head.



Steel-Toe Boots

- Wear steel-toe boots to protect feet from falling debris.



Work Gloves

- Wear work gloves to protect your hands from sharp and rough edges.



Dust Mask

- Wear a dust mask to prevent breathing potentially harmful dust.



2.11. Safety Equipment

The following safety equipment should be kept on site:

Fire Extinguisher

- Provide a fire extinguisher for use in case of an accident. Store in a highly visible and accessible place.



First-Aid Kit

- Have a properly-stocked first-aid kit available for use should the need arise, and know how to use it.



2.12. Safety Decals

- Keep safety decals clean and legible at all times.
- Replace safety decals that are missing or have become illegible. See decal location figures that follow.
- Replaced parts must display the same decal(s) as the original part.
- Replacement safety decals are available **free of charge** from your distributor, dealer, or factory as applicable.

2.12.1 Decal Installation/Replacement

1. Decal area must be clean and dry, with a temperature above 50°F (10°C).
2. Decide on the exact position before you remove the backing paper.
3. Align the decal over the specified area and carefully press the small portion with the exposed sticky backing in place.
4. Slowly peel back the remaining paper and carefully smooth the remaining portion of the decal in place.
5. Small air pockets can be pierced with a pin and smoothed out using the sign backing paper.

2.12.2 Safety Decal Locations and Details

Replicas of the safety decals that are attached to the conveyor and their messages are shown in the figure(s) that follow. Safe operation and use of the conveyor requires that you familiarize yourself with the various safety decals and the areas or particular functions that the decals apply to, as well as the safety precautions that must be taken to avoid serious injury, death, or damage.

Figure 2. Safety Decal Locations

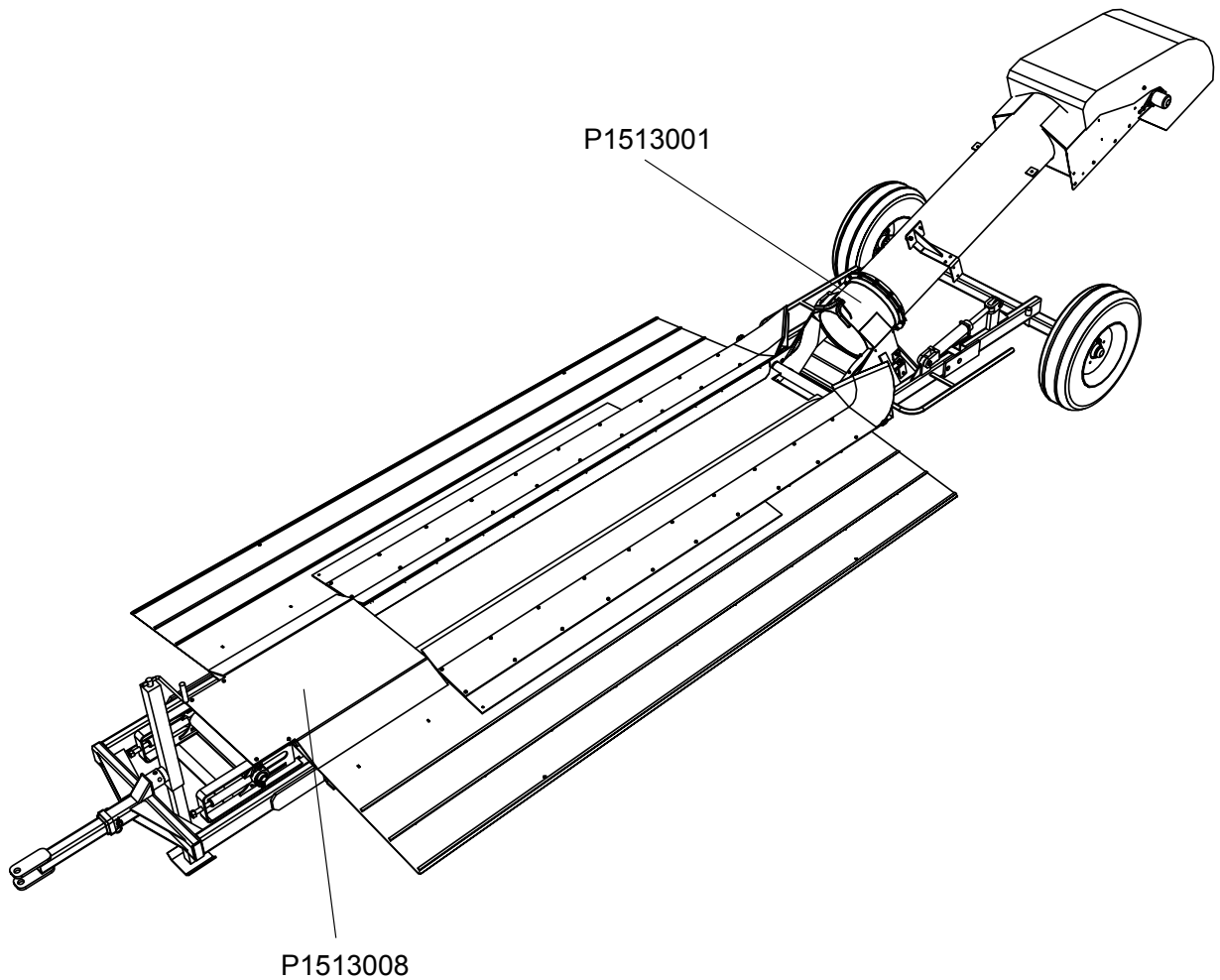
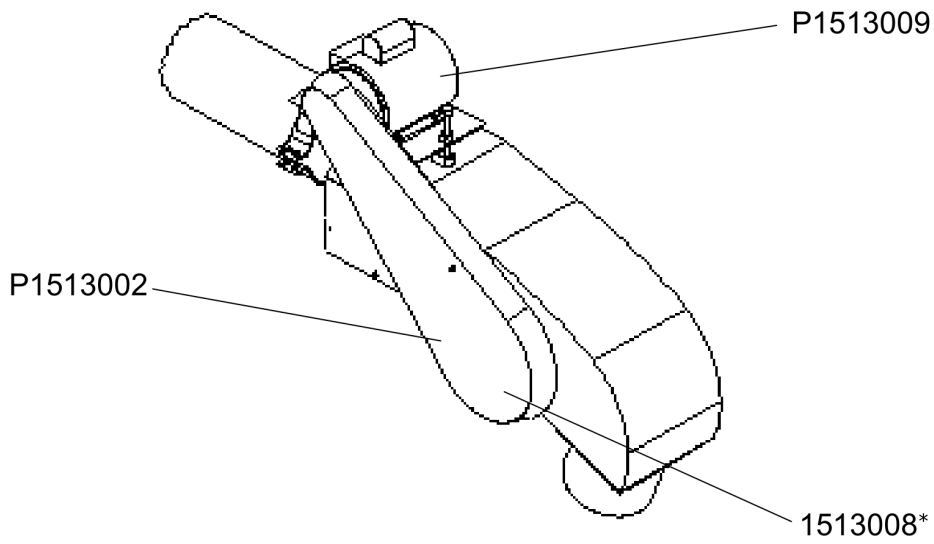

Figure 3. Electric Top Drive Safety Decal Locations



* behind guard

Figure 4. Hydraulic Top Drive Safety Decal Locations

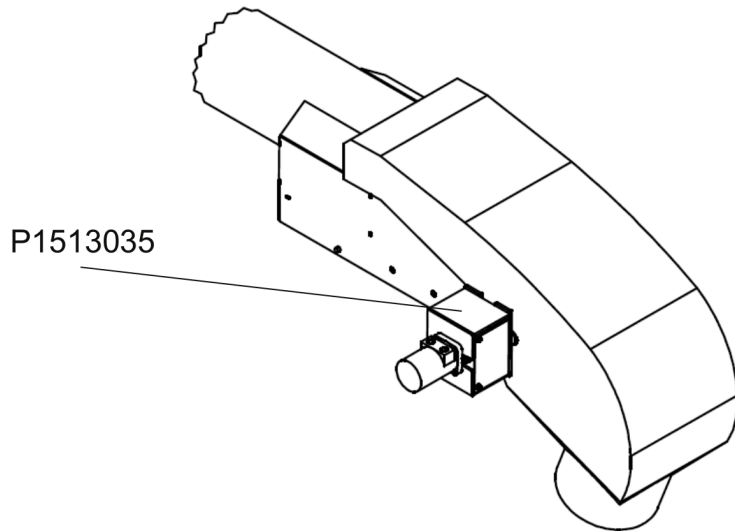

Table 1. Safety Decals









Part Number	Description
P1513001	<div style="border: 2px solid black; padding: 10px;"> <div style="background-color: #f4a460; text-align: center; padding: 5px; border: 1px solid black;">  WARNING </div> <div style="display: flex; justify-content: space-around; margin-top: 10px;"> <div style="text-align: center;">  </div> <div style="text-align: center;">  </div> </div> <div style="margin-top: 10px;"> <p>To prevent serious injury or death:</p> <ul style="list-style-type: none"> • Read and understand the manual before assembling, operating, or maintaining the equipment. • Only trained personnel may assemble, operate, or maintain the equipment. • Children and untrained personnel must be kept outside of the work area. • Do not modify the equipment. Keep in good working order. • If the manual, guards, or decals are missing or damaged, contact factory or dealer for replacements. • Lock out power before performing maintenance. • To prevent equipment collapse, support equipment tube while disassembling certain components. • Electric motors must be grounded. Disconnect power before resetting overloads. </div> </div>



Table 1 Safety Decals (continued)

Part Number	Description
P1513002	<div style="border: 2px solid black; padding: 10px;"> <div style="background-color: #f4a460; text-align: center; padding: 5px;">  WARNING </div> <div style="display: flex; justify-content: space-around; align-items: center; margin-top: 10px;"> <div style="text-align: center;">  </div> <div style="text-align: center;">  </div> </div> <div style="text-align: center; margin-top: 10px;"> <p>ENTANGLEMENT HAZARD</p> <p>To prevent serious injury or death:</p> <ul style="list-style-type: none"> • Keep body, hair, and clothing away from rotating pulleys, belts, chains, and sprockets. • Do not operate with any guard removed or modified. Keep guards in good working order. • Shut off and remove key or lock out power source before inspecting or servicing machine. </div> </div>
P1513008	<div style="border: 2px solid black; padding: 10px;"> <div style="background-color: #f4a460; text-align: center; padding: 5px;">  WARNING </div> <div style="display: flex; justify-content: space-between; align-items: center; margin-top: 10px;"> <div style="text-align: center;">  </div> <div style="text-align: center;"> <p>MISSING GUARD HAZARD</p> <p>To prevent serious injury or death, shut off power and reattach guard before operating machine.</p> </div> </div> <div style="margin-top: 10px;">  </div> </div>

Table 1 Safety Decals (continued)

Part Number	Description
P1513009	<div style="border: 1px solid black; padding: 5px;"> <div style="display: flex; justify-content: space-between; align-items: center;"> <div style="text-align: center;">  </div> <div style="text-align: center;">  <p>WARNING</p> </div> </div> <div style="margin-top: 5px;"> <p>ELECTROCUTION HAZARD To prevent serious injury or death:</p> <ul style="list-style-type: none"> • Only qualified personnel should service electrical components. • Disconnect and lockout power before inspecting or servicing unit. • Keep electrical components in good repair. </div> <div style="margin-top: 10px; text-align: center;">  </div> </div>
P1513035	<div style="border: 1px solid black; padding: 5px;"> <div style="text-align: center; margin-bottom: 5px;">  <p>WARNING</p> </div> <div style="display: flex; justify-content: space-around; align-items: center;"> <div style="text-align: center;">  </div> <div style="text-align: center;">  </div> </div> <div style="margin-top: 5px;"> <p>HIGH PRESSURE FLUID HAZARD Hydraulic fluid can cause serious injury if it penetrates the skin. If it does, see a doctor immediately.</p> <ul style="list-style-type: none"> • Relieve system pressure before repairing, adjusting or disconnecting. • Wear proper hand and eye protection when searching for leaks. Use wood or cardboard instead of hands. </div> </div>



3. Features

This section covers the main features of the conveyor.

Figure 5. Typical Driveover PitStop Components

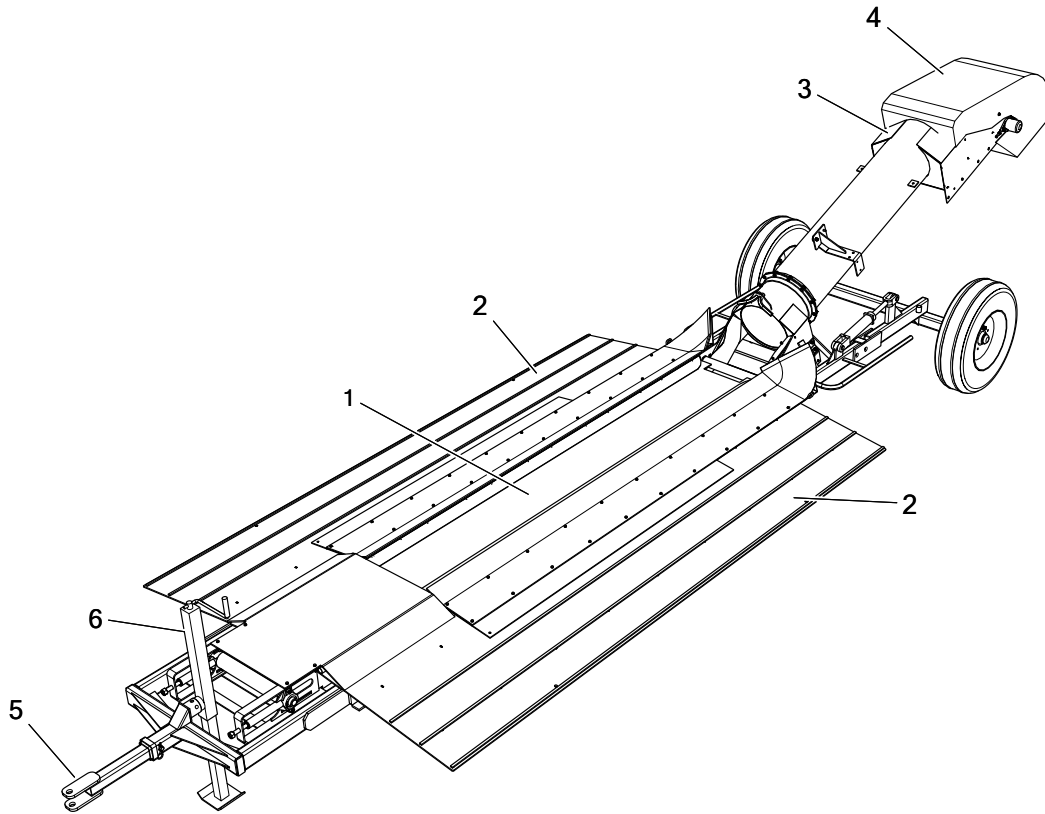

Table 2. Typical Driveover PitStop Components

ITEM	DESCRIPTION
1	Intake Hopper
2	Hopper Side
3	Spout Assembly

ITEM	DESCRIPTION
4	Hood
5	Hitch
6	Jack

4. Transport



Before continuing, ensure you have completely read and understood this manual's Safety section, in addition to the safety information in the section(s) below.

4.1. Transport Safety

WARNING

- Check with local authorities regarding transport on public roads. Obey all applicable laws and regulations.
- Always travel at a safe speed, never exceeding 20 mph (32 km/h). Reduce speed on rough surfaces. Use caution when turning corners or meeting traffic.
- Yield to other drivers and allow faster traffic to pass.
- Make sure the SMV (slow moving vehicle) emblem and all the lights and reflectors that are required by local authorities are in place, are clean, and can be seen by all over-taking and oncoming traffic. Always use hazard-warning flashers on tractor/towing vehicle when transporting unless prohibited by law.
- Do not transport during times of limited visibility such as fog, snow, or heavy rain. Take extra precautions at night and at dusk.
- Keep others away from the transport vehicle and conveyor.
- Do not allow riders on the conveyor or towing vehicle during transport.
- Attach to a proper towing vehicle with a pin and retainer. Always attach safety chain(s).
- Empty conveyor of all grain before transporting. Transporting a full conveyor will place excessive loads on the tube, frame, axle, hitch, and tow vehicle.
- Do not transport on slopes greater than 20°.
- Do not transport with an under-inflated tire(s).
- If the conveyor wheels are partially or fully buried in snow or grain, failure to clear area around the wheels before transporting may cause damage to the conveyor or result in serious injury.

4.2. Transport Preparation

1. It is not recommended that the conveyor be transported faster than 20 mph (32 km/h). [Table 3](#) references the acceptable transport speed as per the ratio of tractor weight versus conveyor weight. See Specifications for conveyor weights.



WARNING

A weight imbalance between the and the towing vehicle could result in a collision from reduced stability, handling, and braking ability.

2. Ensure the conveyor will clear any overhead obstructions or electrical wires prior to transporting. Refer to Specifications for the transport height of your conveyor.
3. Longer conveyors have a large turning radius. Allow ample room for turning as the discharge end may swing dramatically. Allow all oncoming traffic to pass before turning right or left.



**WARNING**

A collision with an oncoming vehicle could occur if the conveyor discharge swings into the opposing lane.

Table 3. Speed versus Weight Ratio

Road Speed	Weight or fully equipped or loaded implement(s) relative to weight of towing machine
Up to 32 km/h (20 mph)	1 to 1, or less
Up to 16 km/h (10 mph)	2 to 1, or less
Do not tow if	More than 2 to 1

4.3. Transport Procedure

1. Align the tongue of the tow unit with the front of the machine while backing up.
2. Set the park brake before dismounting.
3. Install the hitch assembly in the frame and secure with the anchor pin and retainer.
4. Install the jack and secure with the anchor pin.
5. Attach the hydraulic lines if required.
6. Lower the wheel assembly and raise the rear frame. Secure in position with the lock pin and retainer, see Figure 4.1.

Figure 6. Wheel Assembly Anchor Pins



7. Raise the hitch, using the jack.
8. Back the tow unit to align under tongue.
9. Attach to the towing vehicle.
10. Check that hitch is connected with pin and secured with hairpin.
11. Connect safety chains or cables and cross under the hitch.
12. Raise jack.
13. Connect wiring harness if equipped with optional lighting package.
14. Reverse above procedure when unhooking machine.

Note

Remove and stow jack if transporting over rough terrain.

15. When transporting this conveyor with a truck, be sure that it is minimum 1 ton rated and follow these procedures.

Figure 7. Transport Configuration



5. Placement



Before continuing, ensure you have completely read and understood this manual's Safety section, in addition to the safety information in the section(s) below.

5.1. Placement Safety



- Empty the conveyor before raising, lowering, or positioning.
- Move the conveyor into position slowly. Do not unhitch and attempt to move by hand.

5.2. Positioning the Pitstop

The Pitstop can be operated on almost any reasonably flat and level area as long as the transport vehicles can align themselves with the Pitstop. Follow this procedure when setting up and converting the Pitstop from transport to operating configuration.

Note

Due to the length of many trailers, positioning the Pitstop on bowed ground may result in trailer clearance issues.

1. Be sure that there is sufficient room and clearance to back up to the Pitstop.
2. Be sure the Pitstop is placed in an area with sufficient space for the transport vehicles to maneuver for unloading so that grain can be easily removed from the discharge.
3. Move the Pitstop into its required position.

NOTICE

The ground should be firm so the frame does not push into the ground and cause damage to the Pitstop or unloading trucks.

4. Set the park brake before dismounting the towing vehicle.
5. Unhook the Pitstop from the towing vehicle and adjust the jack until the Pitstop rests on the ground.
6. Remove the jack, hitch, and safety chain.
7. Raise the frame slightly and release the load on the transport lock pin.
8. Remove the transport lock pin.

Note

Stow the pin by placing it in the tube bracket on the frame.

9. Remove the wheel assembly anchor pins and stow.
10. Lower the Pitstop to the ground.
11. Position other equipment to remove grain from the discharge.
12. Reverse the above procedure when preparing the Pitstop for moving or transporting.

5.3. Truck Positioning

The Pitstop is designed with the frame in the form of a ramp and a hopper with collapsible sides to facilitate truck positioning.

1. Use the winch to lower the hopper sides.
2. Drive the truck over the intake hopper.
3. Center the truck discharge over the conveyor belt.
4. Raise the sides of the hopper.

NOTICE

Ensure that hopper sides (flaps) are in full down position before driving truck onto or off of the conveyor.

5.4. Lift Valve

1. Before starting, all operators should familiarize themselves with the location and function of the controls.
2. Lift the handle to raise the frame. Move the handle down to lower the frame and raise the wheel.
CAUTION Keep clear of the pitstop when raising or lowering.
3. Secure place with a hair pin washer before transporting.

Figure 8. Lift Valve

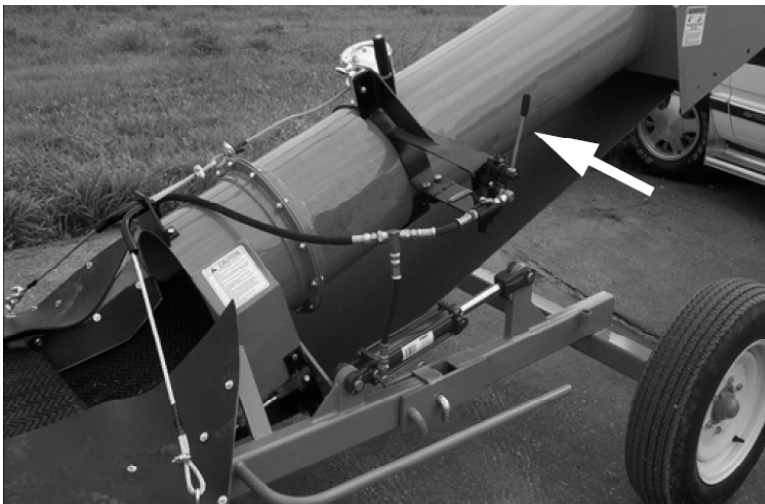

5.5. Collapsible Hopper Control

The Pitstop is designed with a collapsible hopper cloth to allow it to go under low discharge units. Turn the winch handle, located on the conveyor tube, to raise or lower the collapsible hopper.



6. Operation



Before continuing, ensure you have completely read and understood this manual's Safety section, in addition to the safety information in the section(s) below.

6.1. Operation Safety



- Keep away from rotating and moving parts, including the conveyor belt, drive components, shafts, and bearings.
- Do not enter the grain bin while the conveyor is operating.
- Always operate with guards, covers, and shields in place.
- Have another trained person nearby who can shut down the equipment in case of accident.
- Keep the work area clear of bystanders.
- Keep the work area clean and free of debris.
- Ensure maintenance has been performed and is up to date.



Refer to your bin operation manual for specific operating and safety information for your bin.

6.2. Start-up and Break-in

Although there are no operational restrictions on the conveyor when used for the first time, it is recommended that the following items be checked during the first hours of operation.

1. Check that the conveyor intake and discharge areas are free of obstructions.
2. Check conveyor belt alignment to ensure preset alignment does not vary under loaded conditions. See Maintenance Section for alignment instructions.
3. Check the conveyor belt tension. See Maintenance Section for tension instructions.
- ➔ 4. **Electric Drive Models:** Check the drive belt tension and alignment. See Maintenance Section for instructions.
5. Check the pinch roller bearings on the top drive pinch roller are not tight.
6. Visually inspect the conveyor, see Visual Inspection in Maintenance Section.
7. Check tightness of all bolts/nuts, fasteners, and hardware (re-torque if necessary).
8. Start the conveyor and operate normally, refer to power source instructions for further detail.
9. Be aware of unusual sounds. If any are heard, determine the source and stop the conveyor. Lock out and correct the problem before resuming work. If you are unsure of the problem or procedure, contact your local dealer.
10. Do not run the conveyor for long periods of time without material on the conveyor belt because it increases wear. Try to run only when moving material.
11. Stop the conveyor when it is empty of grain and lockout power, lower fully.

Important

After the initial start-up and inspection, the conveyor should be shut down and visually inspected (see Maintenance Section) after approximately ten hours of operation.

6.3. Operation - Electric Motor Models

➡ When equipped with an Electric Motor:

1. Turn the electric motor on.
2. Run until the conveyor is empty.
3. Turn off motor and lock out power source.
4. Unplug the power cord, wrap around the equipment and secure to prevent dragging, especially when transporting or placing the conveyor.

6.4. Operation - Hydraulic Motor Models

1. Place all tractor controls in neutral.
2. Start the tractor and run at low idle.
3. Engage the tractor hydraulic control lever and increase the engine to desired speed.

Note

The correct operation of a hydraulic system is directly linked to the pump's ability to supply the correct oil flow and pressure. If you cannot obtain the correct belt speed, check with your dealer to ensure the power unit is delivering the correct oil volume and pressure.

4. Run until the belting is empty.
5. Reduce tractor engine speed to low idle.
6. Place hydraulic control lever in neutral.
7. Shut off engine and remove ignition key.
8. Disconnect hydraulic hoses, and wrap hose around frame to prevent dragging.

6.5. Conveyor Belt Speed

The best results are obtained when the input drives are set to provide a conveyor belt speed of 500 to 600 ft/min on the 1500 series, and 600 to 650 ft/min on the 1800, 2000, and 2400 Series.

Count the number of belt revolutions per minute to determine belt speed. See Specifications for belt length.

Note

Use the connector splice as a reference when counting belt revolutions.

To calculate, for example, 600ft/minute belt speed for a 47ft belt:

$$\frac{\text{BeltSpeed}}{\text{BeltLength}} = \frac{600}{47} = 12.76$$

Therefore, 12.76 or approximately 13 belt passes per minute will provide a 600ft/min belt speed.

Contact your dealer or the factory for the appropriate drive components to give the recommended belt speed.

If the belt speed is too low, conveyor may leak around transition area.



6.6. Emergency Shutdown

In an emergency situation:

1. Stop or shut down the power source immediately and lock out all power.
2. Stop the flow of material (if applicable).
3. Ensure the machine components come to a stop before inspecting.
4. Correct the emergency situation before resuming work.

6.7. Restarting with a Full Tube

When the conveyor is shut down inadvertently or due to an emergency, the tube may still be filled with grain.

1. With the power source locked out, remove as much of the grain as possible from the tube and intake using a shop vacuum or other tool. Do not use your hands.

NOTICE

Starting under load may result in damage to the conveyor.

2. If guards or covers have been opened or removed, close or replace them before restarting the unit.
- ➡ 3. **Electric and Gas Drive Models:** It may be necessary to tighten the drive belts slightly to handle the heavier than normal loads.
- ➡ 4. **Gas and Hydraulic Drive Models:** Since the start-up torque loads are so much higher than normal when the conveyor belting is full, restart at low speed. Do not let the conveyor belt drive roller spin on the belt if conveying belt does not start moving immediately. This will damage the drive roller and conveying belt.
5. Once the conveyor has been started, you may resume normal operation.

6.8. Shutdown

When operation has been completed:

1. Once the conveyor is clear of grain, lock out the power source.
2. Lower the conveyor fully.
3. Clean out any remaining grain from the conveyor with a vacuum or sweep out.
4. Clean the entire work area.
5. Remove anchors, supports, and chocks.

6.9. Clean Out

After using your conveyor, follow the clean out steps below to ensure longer belt life and trouble free operation. Failure to clean out the conveyor can cause build up of product on the belt and roller shafts, causing spillage, roller misalignment, and excess wear/damage to the belt.

WARNING

Failure to lock out power can cause severe injury.

1. Remove any product remaining in the hopper and spout with a vacuum or sweep out.
2. Remove debris from shafts, sheaves, and drive belts (as equipped).

- Once the conveyor is empty of all product, check for damage on belt and lacing such as notches or cut outs. Any damage on belt may result in product getting under it creating a build-up. If belt replacement and re-lacing is necessary, refer to the Maintenance Section.

Important

Ensure the conveyor is free from all product and debris to prevent build-up. Any build-up on belt and shaft becomes a source of spillage and can cause belt misalignment with the possibility of belt edges sustaining damage on the fixed structure. Build-up on the hopper and spout will cause the belt to wear faster due to drag.

- Once cleaned out, cover intake to prevent moisture from collecting in hopper.

6.10. Conveying Fertilizer

Fertilizer may be conveyed using the conveyor when strictly operated at a reduced capacity and additional care is taken to thoroughly clean the conveyor after operation.

Important

Fertilizer weakens the belt lacing and warranty is void on all lacing used with fertilizer. The belt lacing may need to be replaced more often if you convey fertilizer.

Additional Operating Requirements

To prevent problems that can be caused by conveying fertilizer:

- Do not allow fertilizer to fill over the edge of the belt. This will allow fertilizer to get under the belt and start building up.
- Reduce the flow if the conveyor belt starts to slip. Denser fertilizers will slow the conveyor belt down due to the weight of the product. Too much material will cause the drive roller to slip and lead to additional wear on the roller.
- Do not move fertilizer with your conveyor in humid, wet or rainy conditions. This will cause buildup of fertilizer under your conveyor belt.

Additional Clean-Out Procedures

Proper cleaning will help to ensure longer belt life and prevent excess rust formation.

- Run conveyor empty at full speed for 5-10 minutes after conveying fertilizer. This will help ensure that any product that may be under the belt will be cleaned out and prevent build up.

 **WARNING** Do not attempt to manually remove build-up while conveyor is running.

- Run the belt at low idle and inspect for damage on the belt and lacing, such as notches or cut outs caused by mice and normal wear. Any damage on the belt may result in fertilizer getting under the belt creating a buildup. Consider replacing the conveyor belt if it is in poor condition. If equipped with an electric motor, inspect on the belt return side with the electric motor not running. Turn on the conveyor to expose the belt that was previously in the tube. Turn off the conveyor and inspect the belt on the belt return, along with the lacing.
- Shutdown and lockout power to the conveyor and vacuum or sweep out any remaining fertilizer from the hopper.
- If buildup is evident on or under the belt, remove the buildup to ensure proper operation of the conveyor. When necessary remove fertilizer buildup from under the belt by scraping and washing the belt.

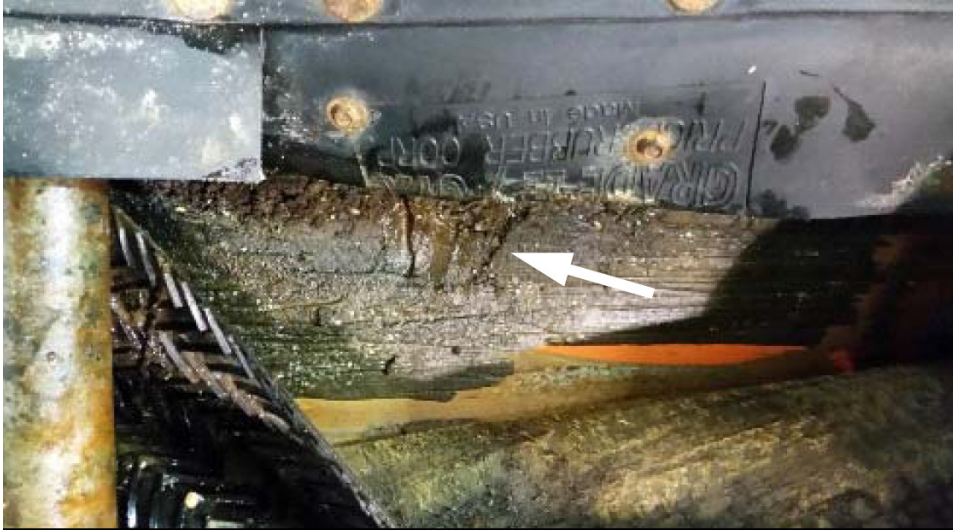

Figure 9. Fertilizer Buildup at Hopper Transition

6.11. Storage

After the season's use, the conveyor should be thoroughly inspected and prepared for storage. Repair or replace any worn or damaged components and perform maintenance as described in the Maintenance Section to prevent any unnecessary downtime at the start of the next season.

To ensure a long, trouble-free life, this procedure should be followed when preparing the unit for storage.

1. Remove all residual material from the hopper and the tube.
2. Stop the machine with the belt lacing inside the tube. This helps prevent the lacing from rusting.
3. Wash the entire conveyor thoroughly using a water hose or pressure washer to remove all dirt, mud, debris, or residue.
4. Inspect all moving or rotating parts to see if anything has become entangled in them. Remove any entangled material.
5. Touch up all paint nicks and scratches to prevent rusting.
6. Check tire pressure and inflate. For inflation pressure, refer to [Section 10. – Specifications on page 54](#).
7. Inspect the conveyor for cracks, tightness of fittings and fasteners, hydraulic hose cracks (if applicable). Have required repairs performed to replace worn or damaged components.
8. Store in an area that is dry, level, free of debris, and away from human activity. Store inside if possible.
9. Cover the motor with waterproof tarpaulin if stored outside to protect from weather.
10. Chock wheels.
11. Support intake on blocks to eliminate prolonged contact with the ground.

7. Maintenance

 Before continuing, ensure you have completely read and understood this manual’s Safety section, in addition to the safety information in the section(s) below.

7.1. Maintenance Safety

WARNING

- Keep components in good condition. Follow the maintenance procedures.
- Ensure the service area is clean, dry, and has sufficient lighting.
- Do not modify any components without written authorization from the manufacturer. Modification can be dangerous and result in serious injuries.
- Shut down and lock out power before maintaining equipment.
- After maintenance is complete, replace all guards, service doors, and/or covers.
- Use only genuine Batco replacement parts or equivalent. Use of unauthorized parts will void warranty. If in doubt, contact Batco or your local dealer.



Before attempting maintenance of any kind:

- Lower the conveyor fully.
- **If equipped with hydraulics:** Before applying pressure to a hydraulic system, make sure all components are tight and that hoses and couplings are in good condition.

7.2. Maintenance Schedule

Proper maintenance habits mean a longer life, better efficiency, and safer operation. Please follow the Maintenance Schedule below. Keep good records of the hours the conveyor has been operated and the maintenance performed.

Daily:
Section 7.3. – Visually Inspect the Equipment on page 32
Section 7.4. – Lubricate the Equipment on page 32
Monthly:
When equipped: Section 7.6. – Inspect Hydraulic Hoses and Fittings on page 33
Section 7.7. – Inspect the Hopper Flashing on page 34
Section 7.9. – Check the Roller Bearings on page 34
Section 7.10. – Check the Roller Lagging on page 34
7.13. Inspect Belt Lacing on page 38



Annually:
Hydraulic Drive Models: Section 7.5. – Oil the Chain Coupler on page 33
Section 7.11. – Tension the Conveyor Belt on page 35
Section 7.12. – Align the Conveyor Belt on page 36
Section 7.16. – Clean and Wash the Equipment on page 40
Section 7.8. – Check the Hydraulic Oil Level on page 34
2–3 Years:
7.14. Replace the Belt Lacing on page 38
As Required:
When equipped: Section 7.17. – Tension the Drive Belts on page 40
When equipped: Section 7.18. – Align the Drive Belts on page 41
When equipped: Section 7.19. – Replace the Drive Belts on page 41
Section 7.20. – Repack the Wheel Bearings with Grease on page 42
7.15. Replace the Conveyor Belt on page 39

7.3. Visually Inspect the Equipment

Check the following during a visual inspection:

1. Ensure all guards are in place and in good working order.
2. Examine the conveyor for damage or unusual wear.
3. Check tightness of bolts/nuts, fasteners, and hardware (re-torque if necessary).
4. Be sure all safety decals are in place and are legible.
5. Check that the discharge and intake area are free of obstructions.
6. Inspect all moving or rotating parts to see if anything has become entangled in them. Remove any entangled material.

 **WARNING** Lock out power before inspecting.

7. **When equipped:** Inspect hydraulic hoses and fittings for leaks and wear. Fix or replace where necessary.
8. Check wheel bolts are tight and examine tires for gashes, uneven wear, or loss of air pressure. See [Section 10. – Specifications on page 54](#) for recommended tire pressure.
9. Check all operating, lifting, and transport components. Replace damaged or worn parts before using the conveyor.

7.4. Lubricate the Equipment

Your equipment can operate at top efficiency only if clean fluids and lubricants are used. Use clean containers to handle all fluids and lubricants. Store them in an area protected from dust, moisture, and other contaminants.

1. Wipe the grease fittings with a clean cloth before greasing to avoid injecting dirt and grit.
2. Use a hand-held grease gun for all greasing.
3. If fittings will not take grease, remove and clean thoroughly.
4. Replace fittings if they are broken or will not accept grease.

Use SAE multi-purpose high-temperature grease with extreme pressure (EP) performance. SAE multi-purpose lithium-based grease is also acceptable.

7.5. Oil the Chain Coupler

The chain coupler is located between the hydraulic motor and the conveyor's drive roller.

Figure 10. Chain Coupler Location

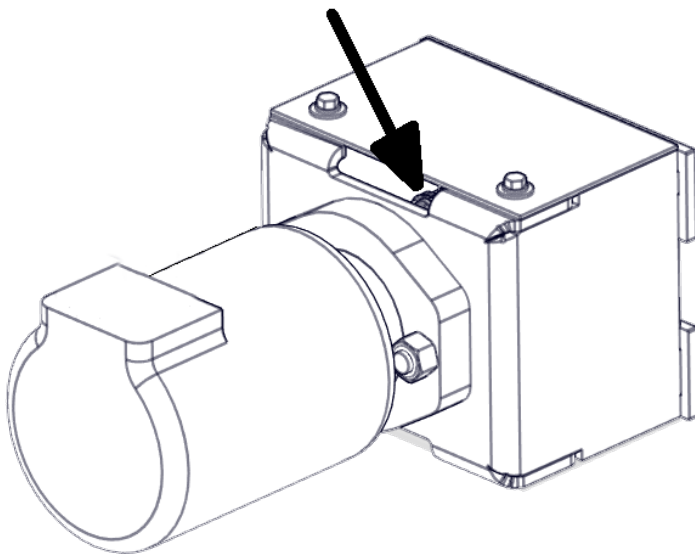

7.6. Inspect Hydraulic Hoses and Fittings

➡ When equipped:

1. Pressurize the system.
2. Using a piece of cardboard or wood, run it along the length of the hose and around all fittings.
⚠ WARNING Escaping hydraulic fluid under pressure will cause serious injury if it penetrates the skin surface.
3. Replace the hose or tighten/replace the fitting if a leak is found. For replacement hoses, refer to [Section 10. – Specifications on page 54.](#)
4. Replace any hose that is badly cut, nicked, abraded, or is separating from the crimped end of the fitting.
5. Secure hoses to the machine.



7.7. Inspect the Hopper Flashing

Check hopper flashing for wear and replace any that are worn. Worn flashing will cause hopper leakage.

7.8. Check the Hydraulic Oil Level

The optional self-contained hydraulic package consists of a pump and reservoir mounted on the right side of the discharge housing. The system is virtually maintenance-free, except for checking the oil level in the reservoir.

To maintain the system:

1. Check the level when the oil is cold by removing the cap from the reservoir.
2. Use SAE all-purpose hydraulic oil for all operating conditions.
3. Fill the tank so that oil is 1" to 1-1/2" (25 mm to 40 mm) from the top.

Note

Reservoir capacity = 2 L (2 qt)

4. After filling, close and secure the cap.

Figure 11. Oil Level



7.9. Check the Roller Bearings

Check the roller bearings for wear. Any rollers making noise, getting hot while running, or that give should be replaced.

7.10. Check the Roller Lagging

Inspect roller lagging to see if it is showing signs of wear.

NOTICE

Operating the conveyor with a damaged roller will result in a damaged conveyor belt.

7.11. Tension the Conveyor Belt

Adjusting your conveyor belt for proper tension helps to ensure trouble-free operation and long belt life.

The conveyor belt only needs to be tight enough to not slip on the drive roller. If the belt is too loose, it will slip on the drive roller making a noticeable sound, slowing the belt down.

The conveyor belt should not be easy to pull from the hopper transition sides, otherwise the belt will require tensioning.

NOTICE

Failure to stop using a conveyor with a slipping belt will damage it and/or the drive roller lagging. In extreme cases, sections of burnt belt will have to be replaced. This type of damage is not covered by warranty.

To set correct conveyor belt tension:

1. Loosen the bearing bolts and jam nut (if included) at the hopper roller, see [Figure 12 on page 36](#).
2. Tighten the tightener bolts equally, use a tape measure to verify. The conveyor belt should deflect 1-2" when pushed down with a 5 lb force, or be difficult to pull from the sides of hopper transition.
3. Tighten the bearing bolts and jam nut (if included).
4. Ensure the hopper roller is tensioned equally by using a tape measure to check both sides.
5. Check the belt tension by running the conveyor for one minute. If the conveyor belt is not slipping, then proceed to next step; otherwise repeat from step 1.
6. After the conveyor belt has been tensioned, check the alignment of all rollers, see [Section 7.12. – Align the Conveyor Belt on page 36](#).
7. If the conveyor belt is still loose after tensioning, the belt needs to be shortened or replaced (depending on wear).



Figure 12. Pitstop Hopper

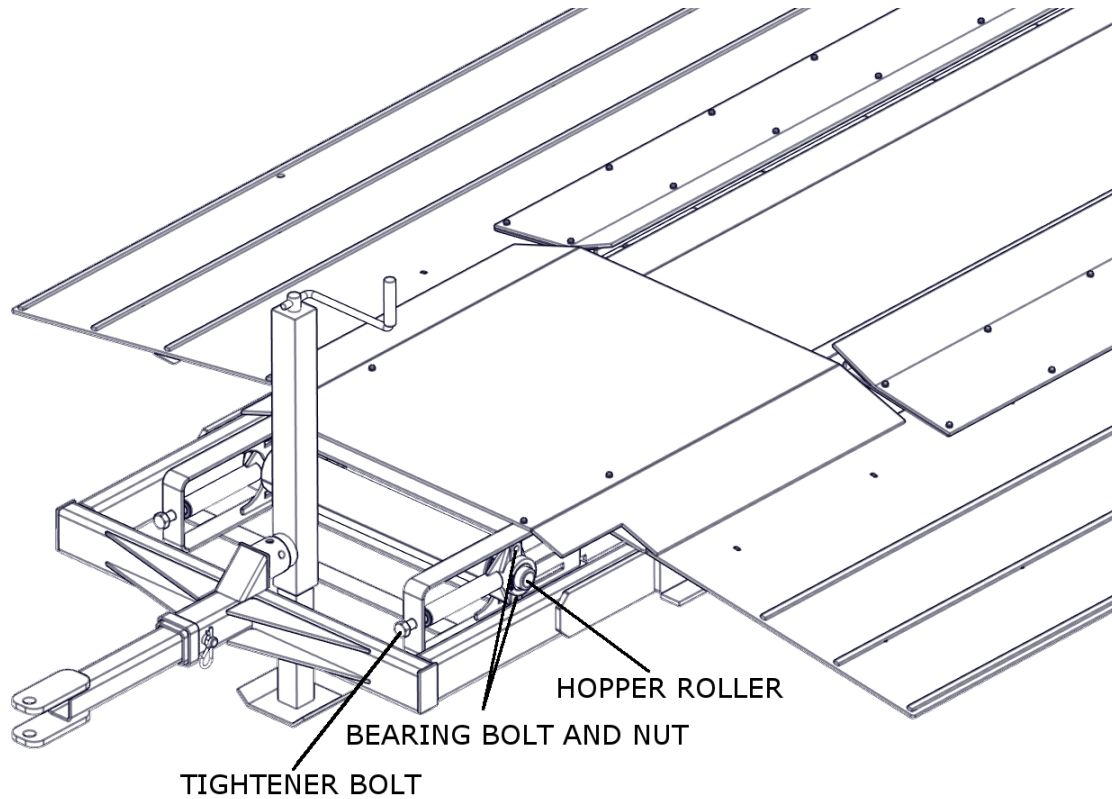

7.12. Align the Conveyor Belt

⚠ WARNING Failure to lock out power can cause severe injury.

Basic Conveyor Belt Alignment:

The conveyor belt will run straight when all of the rollers are straight.

Loosen or tighten the adjustment bolt(s) to align the conveyor belt. Tighten the side the belt has moved toward, or loosen the side the belt has moved away from.

Figure 13. Roller out of Alignment

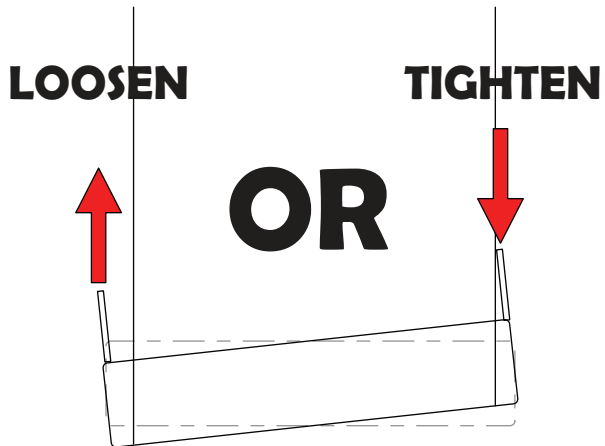
**Before Aligning the Belt:**

- The conveyor must be empty of all grain.
- Wait until the belt makes a complete revolution before adjusting the rollers. Some belts may have uneven edges, appearing misaligned.

To Align the Belt:

If your belt is tracking off-center, follow the sections and steps in the order following to center it.

Figure 14. Belt Tracking to One Side

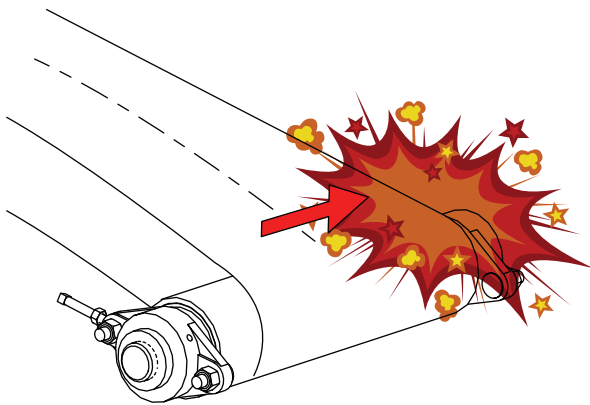
**7.12.1 Adjust the Rollers**

1. Loosen bearing nuts and jam nuts (if equipped).

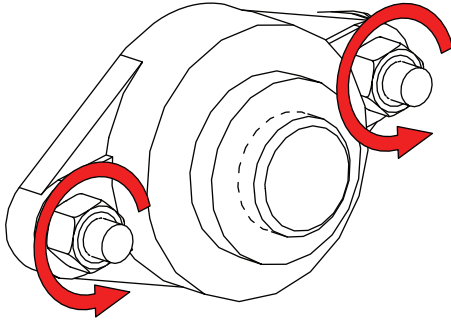

Figure 15. Loosen the Bearing Nuts

2. Rotate adjustment bolt 1/2 turn.

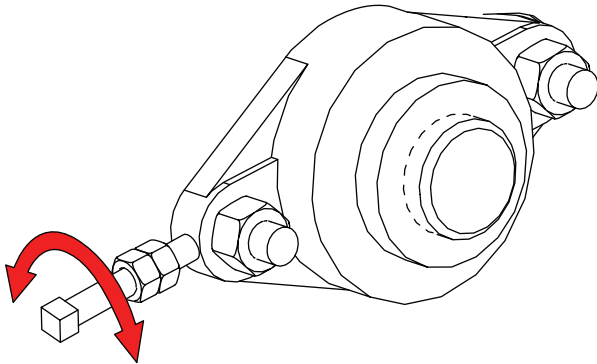
Figure 16. Rotate the Adjustment Bolt

3. Restart conveyor and run empty for 1 minute.
4. Stop the conveyor and remove ignition key or lock out the power source.
5. If the belt has centered, move to next step. If not, repeat Step 2 to Step 4 until the belt is centered.
6. Tighten the bearing bolts and jam nut (if equipped).
7. Replace any guards that were removed.

7.13. Inspect Belt Lacing

Inspect the condition of the belt lacing, if any clips are worn through, replace all lacing.

7.14. Replace the Belt Lacing

1. Rotate the conveyor belt until the lacing is by the hopper or is easily accessible.
2. Loosen the conveyor belt and remove the lacing retainer clip and pin.
3. Using a square and sharp knife, cut the lacing off right behind the lacing clips. The cut belt MUST have a square end.
4. Use a knife to cut Chevron pattern off 1" back from the end of the belt. This ensures that the lacing is centered and fully seated on the belt.
5. Use a lacing tool to install new lacing clips. Lacing clips are one clip shorter than the belt width. For example: the lacing for a 15" wide belt is 14 clips. Center the lacing on the belt and install the lacing as per instructions on the lacing tool.

6. Reattach the conveyor belt ends together. If required, use a ratchet strap clamped to both ends of the belt to cinch the belting ends together. [Figure 17 on page 39.](#)
7. Install the lacing pin and crimp the retainer clips onto each end of the lacing pin. [Figure 18 on page 40.](#)
8. Remove the ratchet strap and tighten the conveyor belt (see “Conveyor Belt Tension”).
9. Check and set the belt alignment (see “Conveyor Belt Alignment”).
10. Engage the conveyor drive. Allow the conveyor to run for 30 seconds, then shut down the conveyor and inspect the lacing.

7.15. Replace the Conveyor Belt

1. Rotate the conveyor belt until the lacing is by the hopper or is easily accessible.
2. Move the tension roller to its loosest position.
3. Pull all the slack to the lacing area.
4. Remove the lacing retainer clip and pin.
5. Attach one end of the replacement belt to the belt end being removed, closest to the hopper.
6. Pull the old belt out and the new belt will be threaded into place.
7. Disconnect the old belt.
8. Reattach conveyor belt ends together. If required, use a ratchet strap clamped to both ends of belt to cinch belting ends together. [Figure 17 on page 39.](#)

Figure 17. Using the Ratchet Strap

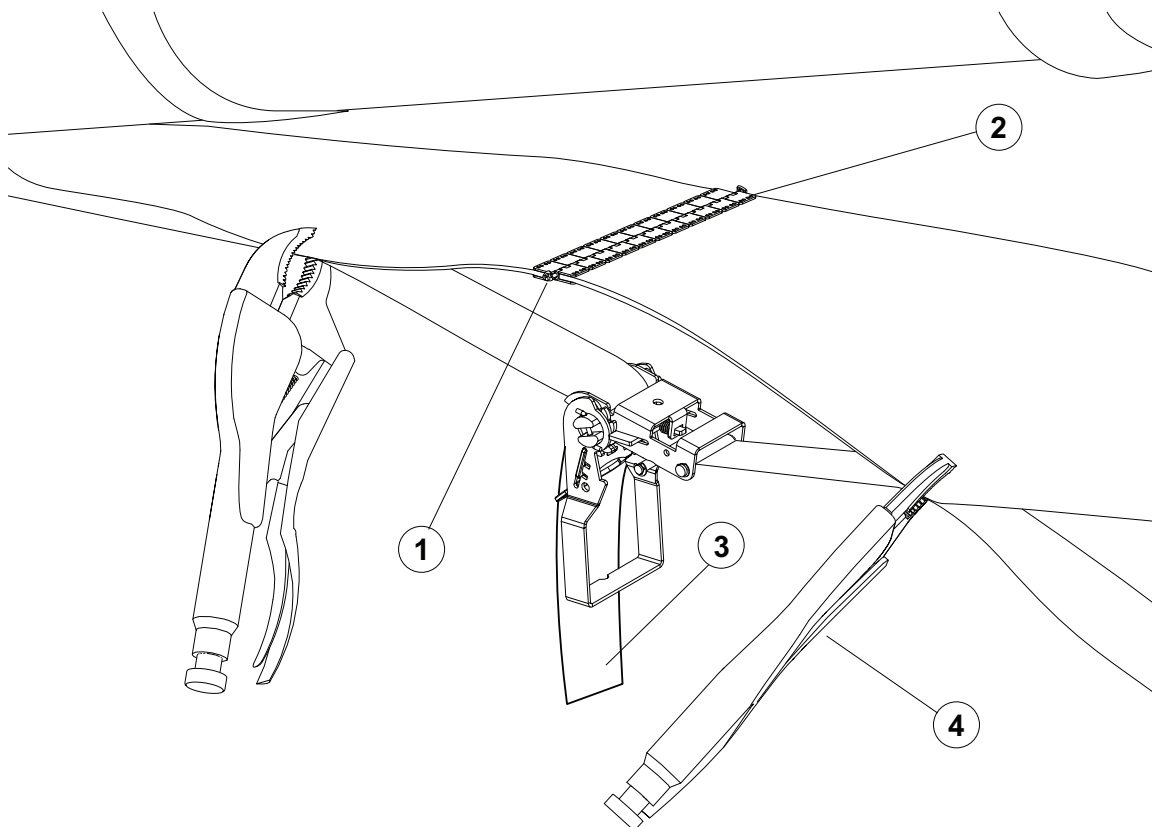

9. Install the lacing pin and crimp the retainer clips onto each end of the lacing pin, see [Figure 18](#).
10. Remove the ratchet strap and tighten the conveyor belt (see “Tension the Conveyor Belt”).
11. Check and set the belt alignment (see “Align the Conveyor Belt”).
12. Engage the conveyor drive. Allow it to run for 30 seconds, then shut down the conveyor and inspect the lacing.

Figure 18. Lacing the Conveyor Belt

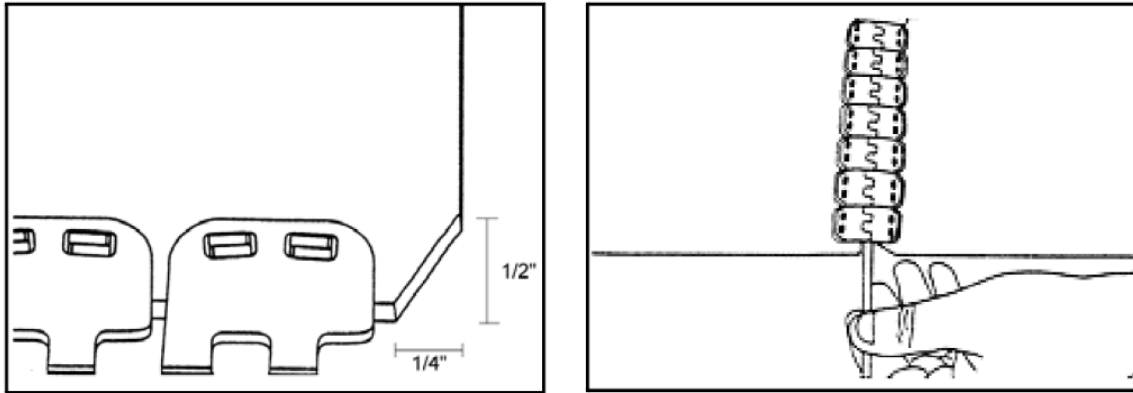

7.16. Clean and Wash the Equipment

1. Clean out excess grain from all areas of the conveyor.
2. Make sure water can drain from the conveyor tube and intake, then wash the tube with a water hose or pressure washer until all dirt, mud, debris, or residue is gone.
3. Provide sufficient time for the water to drain from the conveyor.

7.17. Tension the Drive Belts

➡ When equipped:

1. Remove guard and push on the center of the belt span with a force of approximately 5 lb.
2. The belts will deflect approximately 1" (25 mm) when properly tensioned.

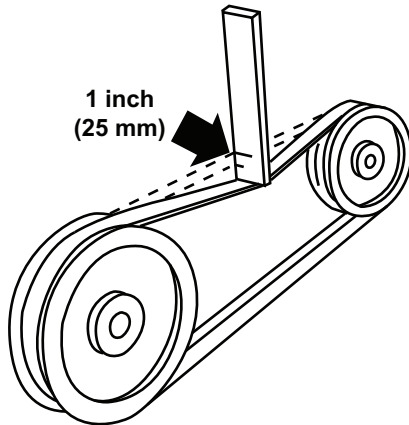
Figure 19. Typical Drive Belt Tensioning

3. Tighten or loosen the drive belts (or idler pulley when equipped) to achieve the proper tension.

Important

The drive belt should be just tight enough to not slip on the drive pulley when operating. If the belt is too loose, it will slip, possibly causing a squeaking sound and slowing the belt down. If the belt is too tight, it will cause excess wear.

4. Reattach and secure guard. Start system to ensure proper operation.

7.18. Align the Drive Belts

➡ When equipped:

1. Lay a straight edge across the pulley faces to check the alignment.
2. Use the pulley hub to move the pulley to the required position for alignment.
3. Tighten the hub bolts to secure pulley on the drive shaft.
4. Check the belt tension.
5. Reattach and secure the guard.

7.19. Replace the Drive Belts

➡ When equipped:

1. Fully loosen the drive belts.
2. Remove and replace the old belts.
3. Tighten the drive belts as described in Belt Tension.
4. Align the drive belts as described in Belt Alignment.
5. Reattach and secure the guard.



7.20. Repack the Wheel Bearings with Grease

1. Block wheels and ensure unit is stable.
2. Remove the wheel bolts and the wheels.
3. Clean wheel and hub mounting surfaces to ensure there is no rust or debris.
4. Remove the wheel bearing and pack with grease. Use SAE multi-purpose high-temperature grease with extreme pressure (EP) performance. SAE multi-purpose lithium-based grease is also acceptable.
5. Tighten the wheel bolts (diagonal pattern) with a torque wrench to 100 ft-lb (± 10 ft-lb) of torque. Inspect to make sure the wheel is sitting flush with the hub.

Figure 20. Diagonal Pattern for 4-bolt and 6-bolt Tires

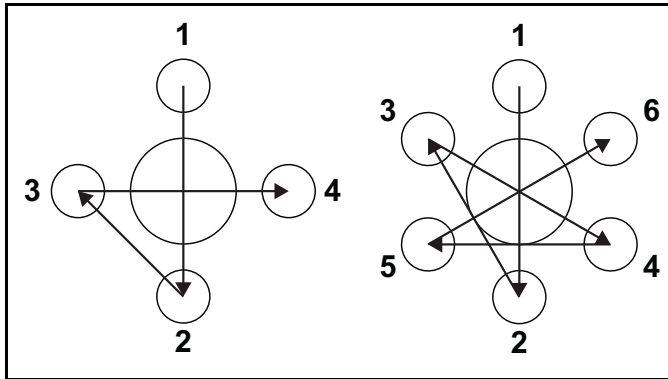

8. Assembly



Before continuing, ensure you have completely read and understood this manual's Safety section, in addition to the safety information in the section(s) below.

8.1. Required Tools

- 1 standard socket set(s)
- 1 wrench set(s)
- 1 hammer and punch
- 1 set(s) of Allen wrenches
- 1 power drill(s)
- 1 self-tapping screw bit (3/8")



8.2. Hydraulic Drive Kit

Refer to [Table 4](#) for the quantity of each component used, and [Figure 21](#) for illustrations of the assembly of the hydraulic top drive. Remove 1/2" locknuts from the right side flange bearings.

1. Remove 1/2" locknuts from flange bearing on drive roller shaft.
2. Install key (1) in drive roller shaft.
3. Slide sprockets (14, 15) and the chain coupling (13) on the drive roller shaft.
4. Attach the hydraulic motor mount (4) to the flange bearing bolts and secure with the 1/2" locknuts removed from the flange bearings.
5. Slide the hydraulic motor (27) into the hub and secure with a key (16).
6. Bolt the hydraulic motor (27) to the motor mount (4) with 1/2" x 2" bolts (7) and 1/2" locknuts (10).
7. Tighten fasteners in sequence starting with the bearing mount, the hydraulic motor, and then the set screws on the sprockets (14,15). Attach motor guards (31) with self-tapping screws (11).
8. Place hydraulic safety sign on the hydraulic motor mount.
9. Install and secure hydraulic hoses (24, 25, 26) with fittings (17-23) to the hydraulic motor (27), flow control valve (29), and single spool valve (28).
10. Mount a keyed shaft guard (not shown) over the left drive roller shaft with a 1/4" x 1/2" bolt, 1/4" lock washer, and a 1/4" flat washer.

Table 4. Hydraulic Drive Components

ITEM	DESCRIPTION	QTY.
1	Key 1/4" x 1-1/2"	1
2	Flow Control Bracket	1
3	Flow Control Tab	1
4	2000 Series PitStop Mount	1
5	Bolt Hex 1/4" x 3"	2
6	Bolt Hex 7/16" x 1-1/2"	2
7	Bolt Hex GR8 1/2" x 2"	2
8	Nut Nylock 1/4"	2
9	Nut Nylock 7/16"	2
10	Nut Nylock 1/2"	2
11	Self-Tapping Screw 1"	4
12	Flat Washer 1/4" USS Plated	4
13	Chain Coupling 5014	1
14	Sprocket 5014 W 1.00 (Key 0.25)	1
15	Sprocket 5014 W 1.25 (Key 0.25)	1
16	Woodruff (#808) 1/4" x 1"	1

Table 4 Hydraulic Drive Components (continued)

ITEM	DESCRIPTION	QTY.
17	Swivel 90 - 1/2 MPT x 1/2 FPT	2
18	Swivel 8 ORB x 1/2 FPT 90	2
20	Swivel 10 ORB x 1/2 FS	2
21	Swivel - 1/2" Straight	1
22	Hex Nipple - 1/2"	2
23	Tee-Swivel -1/2" Fem.	1
24	Hose 1/2 (1'10) 1/2 MPT -1/2 MPT "	1
25	Hose 1/2 (6'7) 1/2 MPT - 1/2 MPT "	1
26	Hose 1/2 (6'7) 1/2 MPT - 1/2 MPT "	1
27	Hyd. Motor (2000) 6.2 CPR	1
28	Valve Single Spool	1
29	Valve Speed Control 1/2 w/Relief	1
30	Check Valve - 1/2" (No Rev. Flow)	1
31	1-1/4 Hyd. Motor Guard 4.5 x 6.25	2

Figure 21. Hydraulic Drive Assembly

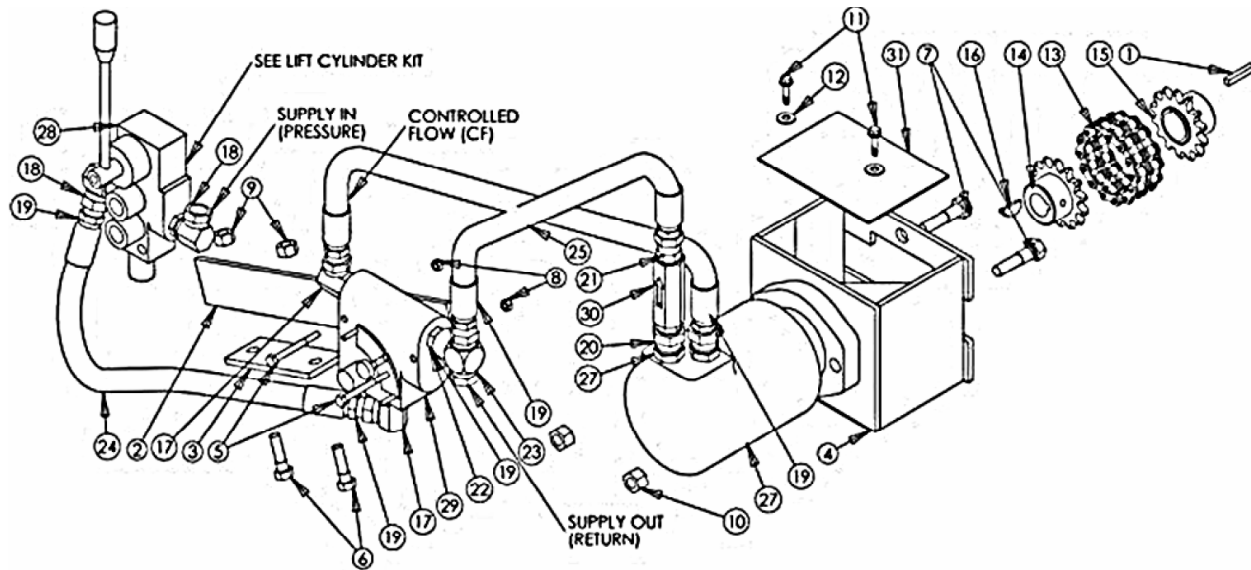

8.3. Electric Top Drive Assembly

Refer to [Table 5 on page 46](#) for the quantity of each component used, and [Figure 22 on page 47](#) and [Figure 23 on page 48](#) for illustrations of the assembly of the electric drive kit.

1. Install two u-clamps (4) with two 1/2" x 2-1/2" bolts (9) and locknuts (10).
2. Position the electric motor clamp (6) on top of the tube and fasten with a 3" u-clamp (5), 1/2" x 2-1/2" bolts (9), and locknuts (10). Ensure it is level before crimping to tube.
3. Install the motor mount plate (1) with the motor mount pin (14) and a 3/16" x 1-1/2" cotter pin (13). Secure by spreading the cotter pin.
4. Position the electric motor (not shown) on the motor mount plate (1) and fasten with the appropriate bolts and locknuts. Leave the bolts finger tight for now.
5. Install a key in the motor shaft. Mount the drive pulley (17) so the hub is flush with the end of the shaft, then secure.
6. Install a key (2) in the drive roller shaft. Mount the driven pulley (16) so the hub is flush with the end of the shaft, then secure.
7. Use a straight edge to align the pulleys.
8. Tighten the motor base bolts.
9. Install the drive belts (15) and set the belt tension by adjusting the 3/4" x 6" tap bolt.

Table 5. Electric Top Drive Components

ITEM	DESCRIPTION	QTY
1	Motor Mount Plate	1
2	Key 1/4" x 1-1/2"	1
3	Spout Assembly	1
4	2 U-Clamp "	2
5	3 U-Clamp "	1
6	Electric Motor Clamp	1
7	Guard Mount	2
8	Bolt Tap 3/4" x 6"	1
9	Bolt Hex 1/2" x 2-1/2" GR8	6
10	Nut Nylock 1/2"	6
11	Self-Tapping Screw 1"	10
12	Flat Washer 1/4" USS Plated	4
13	Cotter Pin 3/16" x 1-1/2"	1
14	Motor Mount Pin	1
15	Belt B 105	2
16	Pulley 2BK140H	1
17	Pulley 2BK34H	1

Table 5 Electric Top Drive Components (continued)

ITEM	DESCRIPTION	QTY
18	Bushing H 1.25	1
19	PitStop Plastic Pulley Guard	1

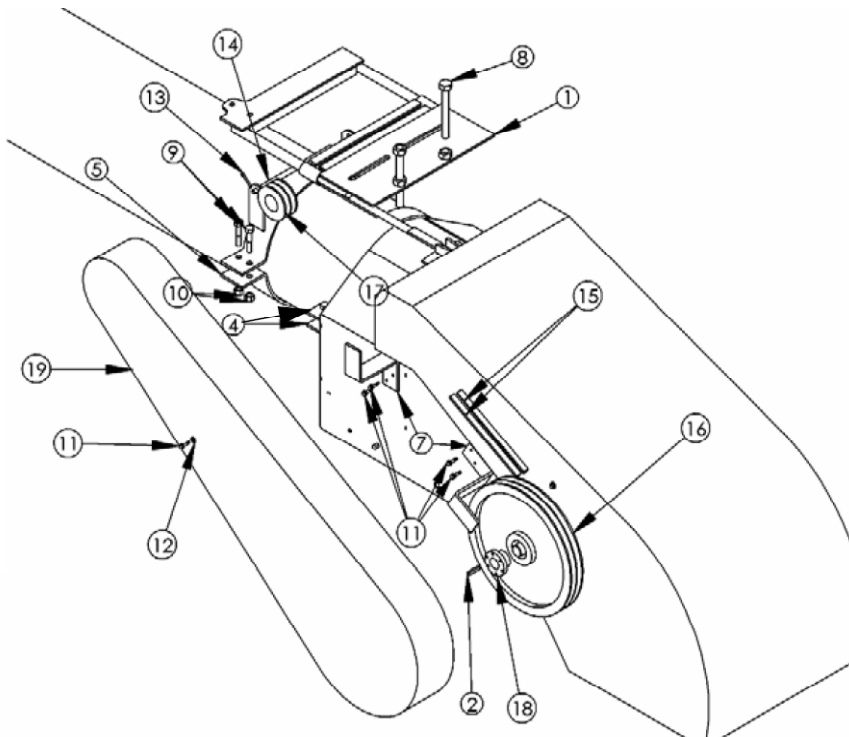
Figure 22. Electric Top Drive Assembly**Note**

The drive belts should deflect 1/2" to 3/4" when pushed on with a 5 lb (2.3 kg) force. Check frequently during the first 10 hours of operation to maintain proper tension.

10. Mount a keyed shaft guard (not shown) over the left drive roller shaft with a 1/4" x 1/2" bolt, 1/4" lock washer, and a 1/4" flat washer.

Note

Be sure the shaft guard is seated against the bearing. It may be necessary to tap cover with a hammer for it to seat properly.

11. Attach safety sign on the plastic pulley guard and on spout plate.
12. Hold plastic pulley guard (19) over the belt and mark suitable mounting bracket locations.
13. Place mounting brackets (7) on plastic guard (19) and drill holes through the bracket and guard. Attach the brackets (7) to the spout with self tapping screws (11).
14. Mount plastic guard (19) to the machine with self-tapping screws (11) and 1/4" flat washers (12) as shown in [Figure 22](#).



Figure 23. Mounting Brackets

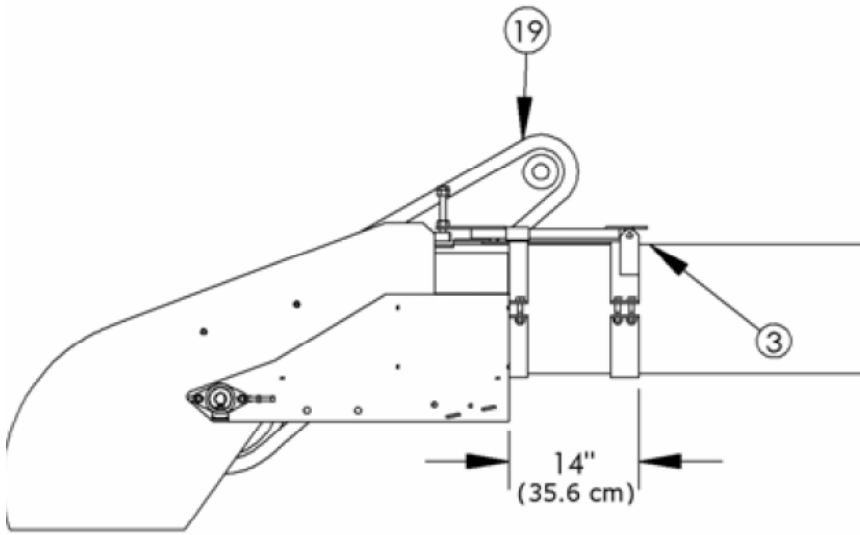

8.4. Electric Wet Kit

Refer to [Table 6](#) for the quantity of each component used, and [Figure 24](#) to [Figure 26](#) for illustrations of the assembly of the electric wet kit.

1. Remove 1/2" locknuts from flange bearings on the side of the drive roller with the keyway.
2. Install key (3) in drive roller shaft.
3. Slide both sprockets (5,12) and the chain coupling (11) on the drive roller shaft.
4. Attach the hydraulic pump mount (4) to the flange bearing bolts and secure with the 1/2" locknuts removed from the flange bearings.
5. Slide the hydraulic pump (22) into the hub and secure with a key (13).
6. Bolt the hydraulic pump (22) to the motor mount (4) with 3/8" x 1-1/2" bolts (6) and locknuts (7).

Important

In [Figure 25](#), note the locations of the pump section port (IN) and the pump pressure port (OUT). Also note the rotation direction of the pump.

7. Tighten fasteners in sequence starting with the mount, the pump, and then the coupler set screws.
8. Attach motor guards (2) with self-tapping screws (8).
9. Use 10" hose clamps (10) to secure the oil reservoir (1) to the tank brackets found on the pump wet kit mount (4).
10. Affix the safety sign as indicated in [Figure 26](#).
11. Install and secure hydraulic hoses and ends (17-21), fittings (14-15), and hose clamp (9) to the oil reservoir (1), pump (22), and valve (23) as illustrated in [Figure 24](#).
12. Mount a keyed shaft guard (not shown) over the left drive roller shaft with a 1/4" 1/2" bolt, 1/4" lock washer, and a 1/4" flat washer.

Table 6. Hydraulic Wet Kit Components

ITEM	DESCRIPTION	QTY
1	Oil Reservoir - 18 L	1
2	1-1/4 Hyd. Motor Guard	2
3	Key 1/4" x 1"	1
4	Pump Wet Kit	1
5	Sprocket 5014 W 0.5 (Key 0.125)	1
6	Bolt Hex 3/8" x 1-1/2"	2
7	Nut Nylock 3/8"	2
8	Self-Tapping Screw 1"	4
9	Clamp Hose 3/4"	1
10	Clamp Hose 10"	2
11	Chain Coupling 5014	1
12	Sprocket 5014 W 1.25 (Key 0.25)	1



Table 6 Hydraulic Wet Kit Components (continued)

ITEM	DESCRIPTION	QTY
13	Woodruff (#405) 1/8" x 5/8"	1
14	90 - 1/2 MPT x 1/2 FPT	1
15	90 - #10 ORB x 1/2 FPT	4
17	Hose End 1/2"	4
18	Hose End 1/2"	1
19	Hose 1/2" Hydraulic (7' 6")	1
20	Hose 1/2" Hydraulic (9' 6")	1
21	Hose 3/4" Hydraulic (36")	1
22	Pump-Parker With Side Ports	1
23	Valve Single Spool	1

Figure 24. Hydraulic Wet Kit Assembly

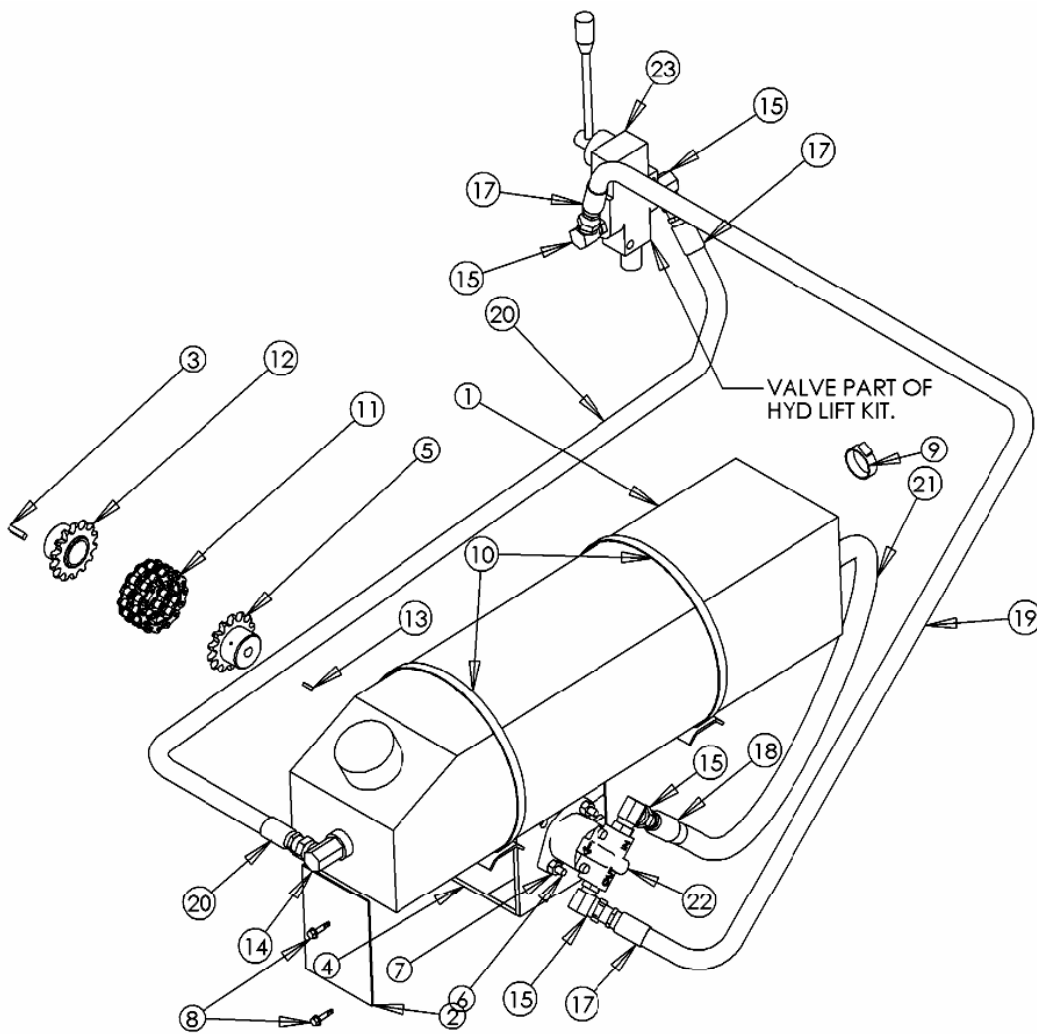

Figure 25. Hydraulic Pump

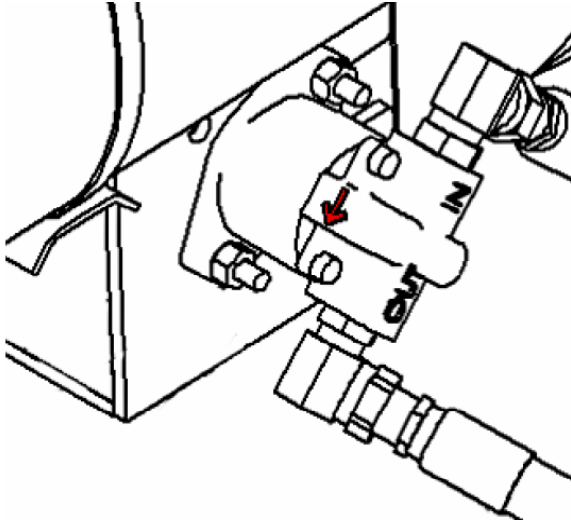

Figure 26. Wet Kit Safety Decal Location



9. Troubleshooting



Before continuing, ensure you have completely read and understood this manual’s Safety section, in addition to the safety information in the section(s) below.



Shut down and lock out all power sources before diagnosing any of the causes or attempting any of the solutions below.

In the following section, we have listed some causes and solutions to some of the problems you may encounter.

If you encounter a problem that is difficult to solve, even after having read through this section, please contact your local dealer or distributor. Before you contact them, please have this operation manual and the serial number from your machine ready.

Conveyor

Problem	Cause	Solution
Low conveying capacity.	Incorrect belt speed.	Verify and adjust belt speed to appropriate speed, see Belt Speed in Operation.
	Conveyor belt slipping.	Tighten conveyor belt, see Conveyor Belt Tension in Maintenance.
	When equipped: Drive belts slipping.	Tighten belts, see Drive Belt Tension in Maintenance.
Conveyor belt slipping.	Conveying belt loose.	Tighten and align belt, see Belt Tension and Belt Alignment in Maintenance.
	Drive roller lagging worn or damaged.	Replace drive roller lagging, see dealer.
	When equipped: Drive belts loose.	Tighten belts, see Drive Belt Tension in Maintenance.
	Belt frozen to tube from operating in high humidity in cold conditions.	Remove conveyor from area of high humidity and warm belt to de-ice.
Excessive conveyor belt edge fraying.	Belt not aligned.	Align belt, see Belt Alignment in Maintenance.
Conveyor belt loose.	Belt stretches over time.	Re-tension belt, see Belt Tension in Maintenance.

		If belt is fully tensioned, you may need to shorten belt and re-lace, see Belt Relacing in Maintenance.
Grain leaking from conveyor hopper.	Belt not aligned (centered).	Align belt, see Belt Alignment in Maintenance.
	Flashing installed incorrectly or worn.	Inspect flashing for wear and replace if required.
	When equipped: Transition filler rings are worn.	Replace transition filler rings.
Grain leaking from conveyor discharge between belt and tube.	Belt not aligned (centered).	Align belt, see Belt Alignment in Maintenance.
Grain leaking from conveyor discharge between hood and belt.	Belt speed is too fast, hood plugging.	Decrease belt speed, see Belt Speed in Operation.

Drive

Problem	Cause	Solution
Drive making noise.	When equipped: Slipping drive belt.	Tighten belts, see Drive Belt Tension in Maintenance.
	Hot shaft, pulley or bearing.	Overheated components indicate a failed bearing that must be repaired.
	Broken drive roller.	Replace damaged component.



10. Specifications

Table 7. Pitstop

	1800 Series	2400 Series
Length	4.5'	5.3'
Width	7.9'	7.9'
Height	2.8'	3'
Belt Length	47'	52'10"
Weight	2970 lb	3260 lb
Power Options		
Hydraulic	6.2 (cu. in.)	8.0 (cu. in.)
Gas	n/a	27 hp
Electric	7.5 hp	10 hp

11. Batco Limited Warranty

This warranty relates to Batco Conveyors (the “Product”) sold by Batco-Rem, (which is a division of Ag Growth Industries Partnership, referred to herein as the “Seller”) and applies only to the first user of the Product (meaning a purchaser directly from the Seller or from an authorized dealer or distributor of the Product, referred to herein as the “Buyer”).

This warranty shall only be effective if properly registered with the Seller in accordance with information provided to the Buyer at the time of sale.

1. The Seller warrants to the Buyer that the Product is free from defects in material and workmanship **under normal and reasonable use.**
2. This warranty applies only to defects in materials and workmanship and not to damage incurred in shipping or handling, through normal wear and tear, or damage due to causes beyond the control of the Seller such as lightning, fire, flood, wind, earthquake, excessive voltage, mechanical shock, water damage, or damage arising out of abuse, alteration, improper assembly, improper installation, improper maintenance or improper repair of the Product.
3. **The warranty period for the Product shall be one year from delivery of the Product to the Buyer where the Product is used in a normal farm operation. The warranty period for the Product shall be 90 days from delivery of the Product to the Buyer where the Product is used in a commercial operation. No warranty is given where the Product was used to convey canola.** In the event that any part incorporated into the Product is manufactured and sold to the Seller by a third party vendor, such part is only warranted to the extent of the warranty given by that third party.
4. The obligations set forth in this warranty are conditional upon the Buyer promptly notifying the Seller of any defect and completing reasonably required documentation and, if required, promptly making the Product available for correction. The Seller shall be given reasonable opportunity to investigate all claims and no Product shall be returned to the Seller or part disposed of until after inspection and approval by the Seller and receipt by the Buyer of written shipping instructions, with transportation charges prepaid.
5. Upon return of the Product, or such part of the Product that requires correction, the Seller shall, at the Seller’s option, either repair or replace the Product or such part. The Seller shall replace or attempt to repair and return the Product or such part within a reasonable period of time from receipt of an approved warranty claim from the Buyer. If the Seller is unable to repair or replace the Product, the Buyer shall be entitled to a credit note in the amount of the purchase price for the Product.
6. The total liability of the Seller on any claim, whether in contract, tort or otherwise, arising out of, connected with, or resulting from the manufacture, sale, delivery, repair, replacement or use of the Product or any part thereof **shall not exceed the price paid for the Product** and the Seller shall not be liable for any special indirect, incidental or consequential damages caused by reason of the installation, modification, use, repair, maintenance or mechanical failure of the Product. **Consequential or special damages as used herein include, but are not limited to, lost or damaged products or goods, costs of transportation, lost sales, lost orders, lost income, increased overhead, labor and incidental costs and operational inefficiencies.**
7. **Notwithstanding anything contained herein to the contrary, the foregoing is the Buyer’s sole and exclusive remedy for breach of warranty by the Seller in respect of the Product. The Seller, for itself, its agents, contractors, employees and for any parent or subsidiary of the Seller, expressly disclaims all warranties, either express or implied, written or oral, including implied warranties of merchantability or fitness for a particular purpose and undertakes no obligation with respect to the conformity of the Product except as set out in the purchase agreement, if any, or marketing materials.**
8. The foregoing warranty is the entire warranty of the Seller to the Buyer and the Buyer shall not be entitled to rely upon any representation or warranty contained in any marketing material of the Seller in respect of the Product. The Seller neither assumes, nor authorizes any other person purporting to act on its behalf to modify or to change this warranty, nor to assume for it any other warranty or liability concerning the Product.

WARRANTY VOID IF NOT REGISTERED





Shipping: 201 Industrial Drive, Swift Current, Saskatchewan S9H 5R4, CANADA

Mailing: Box 1750, Swift Current, Saskatchewan S9H 4J8, CANADA

Toll-Free: (877) 667-7421 (Canada & USA)

Phone: (306) 773-7779

Fax: (306) 778-2524

Email: info@batcomfg.com

Web: www.batcomfg.com

Batco is part of the Ag Growth International group

©Ag Growth International Inc. 2018

Printed in Canada

