



TOP DRIVE FIELD LOADER GRAIN CONVEYOR

1300 P, 1500 P SERIES
OPERATION MANUAL



Read this manual before using product. Failure to follow instructions and safety precautions can result in serious injury, death, or property damage. Keep manual for future reference.

Part Number: P1512121 R0

Revised: 11/3/10

TABLE OF CONTENTS

1. Introduction	3
2. Safety First.....	5
2.1. General Safety	6
2.2. Transport and Placement Safety	7
2.3. Operational and Maintenance Safety	8
2.4. Hydraulic Safety	10
2.5. Electric Motor Safety	10
2.6. Storage Safety	10
2.7. Tire Safety	10
2.8. Safety Decal Locations.....	11
2.8.1. Decal Installation	11
2.8.2. Decal Locations	11
3. Components and Controls	15
4. Transport.....	17
4.1. Pre-Transport Checklist.....	17
4.2. Transport Procedure	17
5. Placement	19
5.1. Under Hopper Bottom Bins	19
5.2. Filling Trucks/Tanks	19
6. Operation	21
6.1. Pre-Operation Checklist	21
6.2. Machine Break-In And Operation	21
6.2.1. Drive Setup	22
6.2.2. Starting Conveyor	22
6.2.3. Conveyor Shutdown	23
6.2.4. Emergency Shutdown	23
6.2.5. Re-starting (Full Tube).....	23
6.2.6. Conveyor Operating Angles	23
6.2.7. Belt Speed	23
6.2.8. Operating Tips	24
7. Storage	25

TABLE OF CONTENTS

- 8. Maintenance..... 27**
 - 8.1. Maintenance Schedule 27
 - 8.1.1. Initial start-up servicing 27
 - 8.1.2. 8 Hours or Daily 27
 - 8.1.3. 40 Hours or Weekly 27
 - 8.1.4. 200 Hours or Annually 27
 - 8.2. Maintenance Checklist 28
 - 8.3. Service & Maintenance Procedures 29
 - 8.3.1. Fluids and Lubricants..... 29
 - 8.3.2. Greasing 29
 - 8.3.3. Conveyor Belt Tension And Alignment 29
 - 8.3.4. Belt Tension Instructions 30
 - 8.3.5. Conveyor Belt Alignment 31
 - 8.3.6. Conveyor Belt Replacement 33
 - 8.3.7. Belt Relacing..... 34
 - 8.3.8. Drive Belt Tension & Alignment (Electric Drive) 35

- 9. Troubleshooting 37**

- 10. Appendix..... 39**
 - 10.1. Top Drive Field Loader Specifications..... 39
 - 10.2. Conveyor Product Chart..... 40

- New Equipment Warranty 41

1. Introduction

Congratulations on your choice of a Batco Conveyor to complement your agricultural operation. This equipment has been designed and manufactured to meet the needs of the discriminating buyer for the efficient movement of grain, pulse crops, fertilizer, and most other granular materials.

Safe, efficient, and trouble-free operation of your conveyor requires that you, and anyone else who will be operating or maintaining the conveyor, read and understand the safety, operation, maintenance, and troubleshooting information in this manual.

➔ Equipment is available in various combinations. In most cases, the following instructions will apply to all machines. Where the assembly information varies, additional instructions will be included and will be indicated with an arrow.

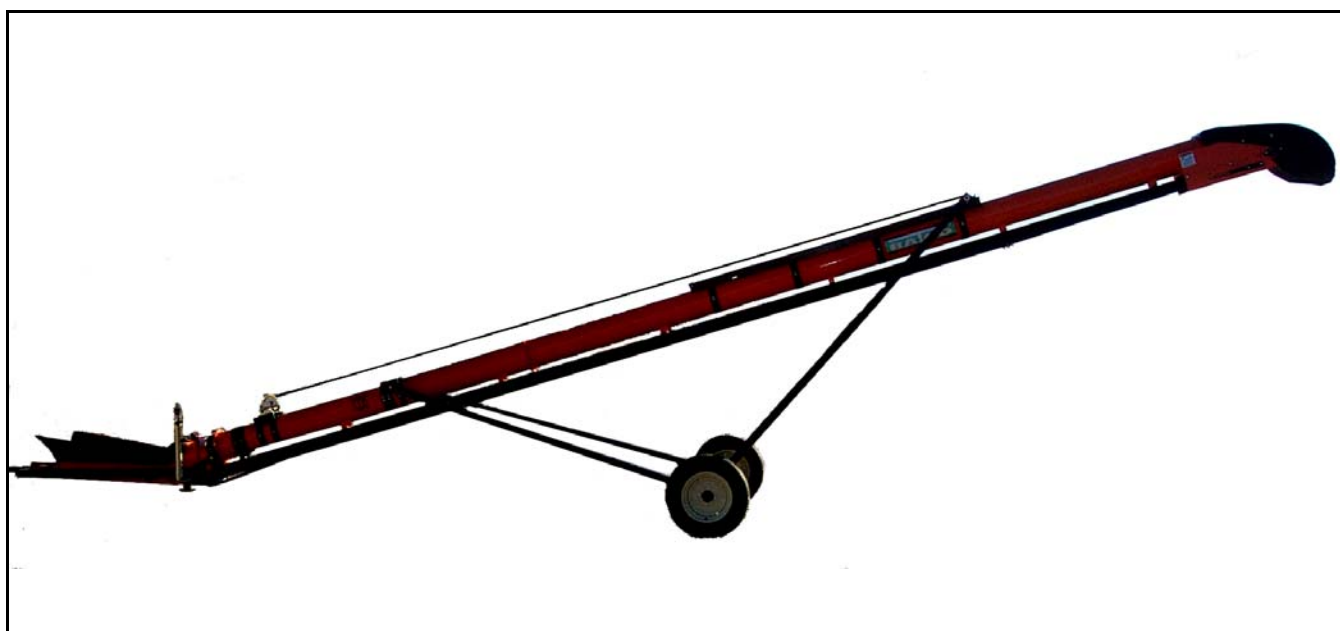

Keep this manual handy for frequent reference and to pass on to new operators or owners. Call your Batco distributor or dealer if you need assistance, information, or additional copies of the manual.

Always give your dealer the serial number of your Batco Grain Conveyor when ordering parts or requesting service or other information.

The serial number plate is located where indicated above by the arrow on the frame. Please mark the number in the space provided for easy reference.

Model#	
Serial #	
Production Year	

2. Safety First



The Safety Alert symbol to the left identifies important safety messages on the product and in the manual. When you see this symbol, be alert to the possibility of personal injury or death. Follow the instructions in the safety messages. Why is SAFETY important to you?

Three big reasons:

- Accidents disable and kill.
- Accidents cost.
- Accidents can be avoided.

SIGNAL WORDS

Note the use of the signal words **DANGER**, **WARNING**, **CAUTION**, and **NOTICE** with the safety messages. The appropriate signal word for each message has been selected using the definitions below as a guideline.

The Safety Alert symbol means ATTENTION, BE ALERT!, YOUR SAFETY IS INVOLVED.

DANGER



Indicates an imminently hazardous situation that, if not avoided, will result in serious injury or death.

WARNING



Indicates a hazardous situation that, if not avoided, could result in serious injury or death.

CAUTION



Indicates a hazardous situation that, if not avoided, may result in minor or moderate injury.

NOTICE

Indicates a potentially hazardous situation that, if not avoided, may result in property damage.

2.1. GENERAL SAFETY

Important: *The general safety section includes instructions that apply to all safety practices. Any instructions specific to a certain safety practice (e.g., assembly safety), can be found in the appropriate section. Always read the complete instructional sections and not just these safety summaries before doing anything with the equipment.*

YOU are responsible for the **SAFE** use and maintenance of your equipment. **YOU** must ensure that you and anyone else who is going to work around the equipment understands all procedures and related **SAFETY** information contained in this manual.

Remember, **YOU** are the key to safety. Good safety practices not only protect you, but also the people around you. Make these practices a working part of your safety program.

- It is the equipment owner and the operator's responsibility to read and understand **ALL** safety instructions, safety decals, and manuals and follow them before assembling, operating, or maintaining the equipment. All accidents can be avoided.
- Equipment owners must give instructions and review the information initially and annually with all personnel before allowing them to operate this product. Untrained users/operators expose themselves and bystanders to possible serious injury or death.
- Use this equipment for its intended purposes only.
- Do not modify the equipment in any way. Unauthorized modification may impair the function and/or safety, and could affect the life of the equipment. Any modification to the equipment voids the warranty.
- Do not allow children, spectators, or bystanders within the work area.
- Have a first-aid kit available for use should the need arise, and know how to use it.
- Provide a fire extinguisher for use in case of an accident. Store in a highly visible place.
- Wear appropriate protective gear. This list includes, but is not limited to:
 - a hard hat
 - gloves
 - protective shoes with slip-resistant soles
 - protective goggles
 - hearing protection
- For Powered Equipment: before servicing, adjusting, or repairing powered equipment, unplug, place all controls in neutral or off position, stop the engine or motor, remove ignition key or lock out power source, and wait for all moving parts to stop.



- Follow good shop practices:
 - keep service area clean and dry
 - be sure electrical outlets and tools are properly grounded
 - use adequate light for the job at hand
 - Think SAFETY! Work SAFELY!



2.2. TRANSPORT AND PLACEMENT SAFETY

- Be sure that conveyor is empty before raising or lowering.
- Check with local authorities regarding transport on public roads. Obey all applicable laws and regulations.
- Always travel at a safe speed, never exceeding 20 mph (32 km/h). Reduce speed on rough surfaces. Use caution when turning corners or meeting traffic.
- Make sure the SMV (slow moving vehicle) emblem and all the lights and reflectors that are required by local authorities are in place, are clean, and can be seen by all over-taking and oncoming traffic. Always use hazard-warning flashers on tractor/towing vehicle when transporting unless prohibited by law.
- Do not allow riders on the machine, towing vehicle, tractor, or skid steer during transport.
- Stay away from overhead obstructions and power lines when operating and transporting. Electrocutation can occur without direct contact.
- Fully lower conveyor before transporting, and only raise when next to storage facility.
- Review the work safety area diagram before starting work.
- Attach a conveyor to towing vehicle with a pin and retainer. Always attach safety chain(s).
- Chock front and rear conveyor and tractor wheels before operating.
- Do not raise the intake end above drawbar, conveyor upending may occur.
- Be familiar with the machine transport hazard area. If anyone enters the hazard area, shut down the machines immediately. Clear the area before restarting.
- Do not transport conveyor on slopes greater than 20°.
- When lowering the auger the track shoe may become stuck; if this happens, do not continue to turn the winch handle counter-clockwise because it will disengage the brake mechanism and create an unsafe condition. Too much slack in the cable may also cause the conveyor to drop suddenly.

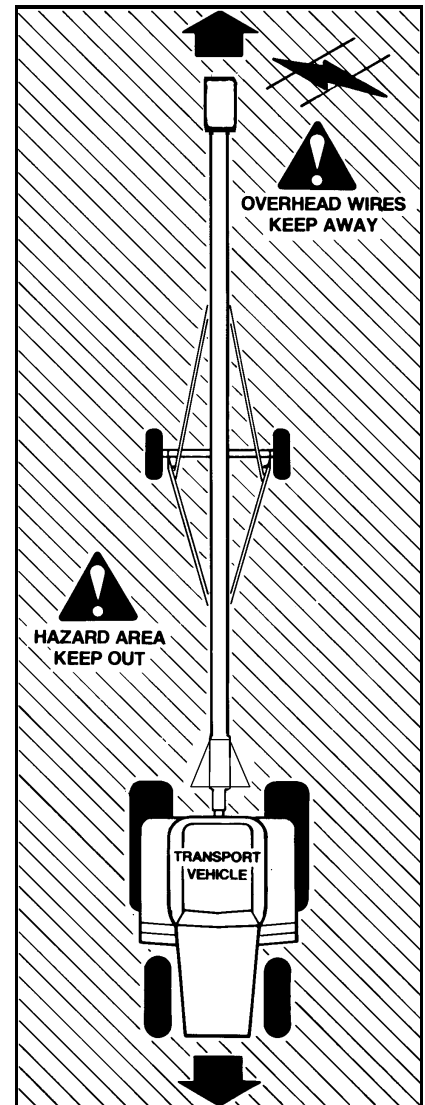

- The winch must make a clicking sound when raising conveyor. If clicking sound stops, retain grip on handle, lower conveyor fully, and repair winch.
- After lowering conveyor, turn handle clockwise 2 clicks to lock winch brake.
- The winch is designed for manual operation only.
- Always keep a minimum of 3 cable wraps on the winch drum.
- Wheels must be free to move when raising or lowering conveyor. Do not use conveyor as a crane or hoist.
- Only move your conveyor with a tractor/towing vehicle. Never move by hand.

2.3. OPERATIONAL AND MAINTENANCE SAFETY

- Keep hands, feet, hair, clothing, and jewelery away from all moving and/or rotating parts.
- Stay away from overhead obstructions and power lines; electrocution may occur without direct contact.
- Do not operate with any of the guards removed.
- The machine is closely balanced. Do not lift unless there is a downward weight on the intake end to prevent upending.
- ➔ • Set park brake on tractor before starting.
- Lower conveyor to its lowest position when not in use.
- Operate conveyor on level ground free of debris. If ground is uneven, anchor the conveyor to prevent tipping or upending.
- Place stands or blocks under the frame before working beneath the machine.
- Always work with a second person around conveyor in case of accident.
- Empty conveyor before raising or lowering.
- Do not get on or beneath conveyor when raising or lowering.
- Do not lift intake above tow bar height or conveyor may upend.
- Be familiar with the machine hazard area shown in Figure 2.1 and 2.2. If anyone enters the hazard area, shut down the machines immediately. Clear the area before restarting.

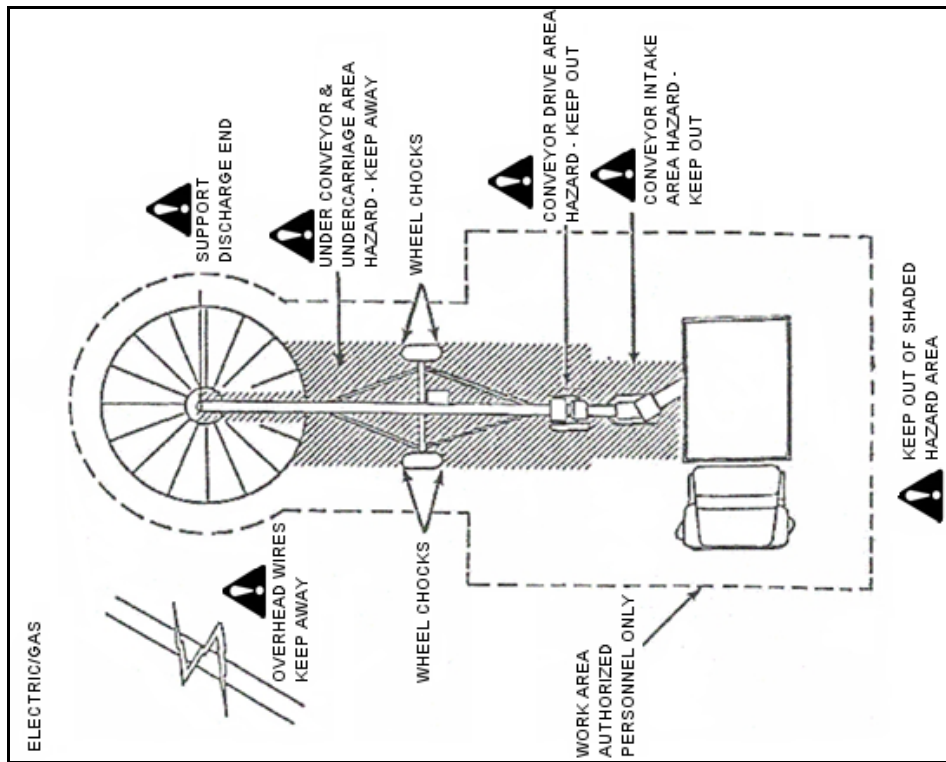

Figure 2.1 Workplace Hazard Area (Electric Area)

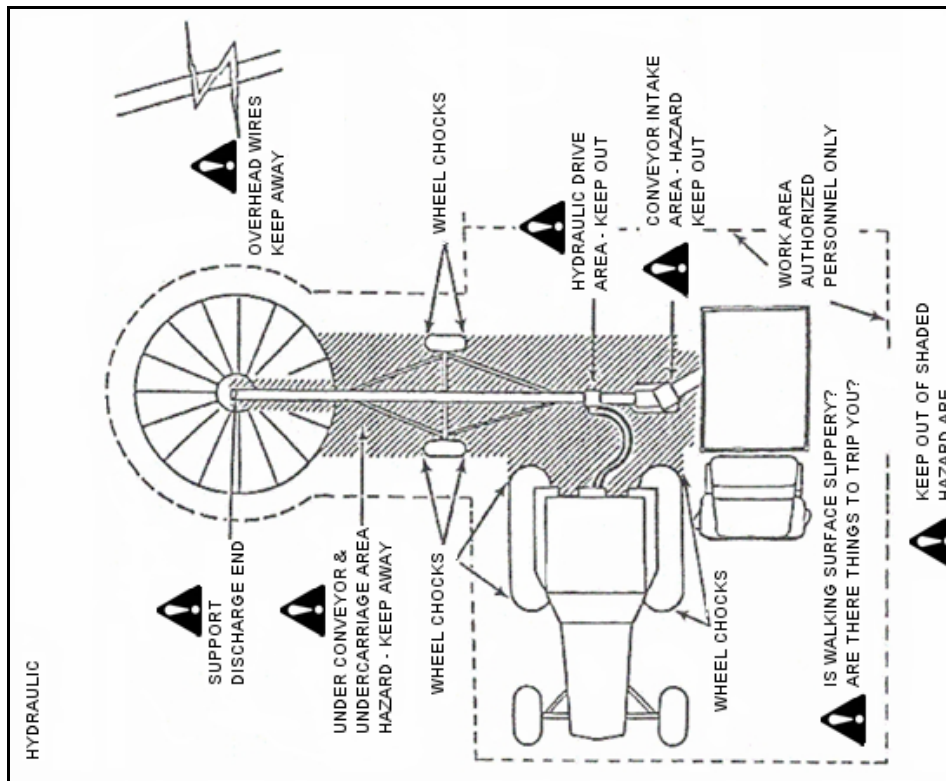
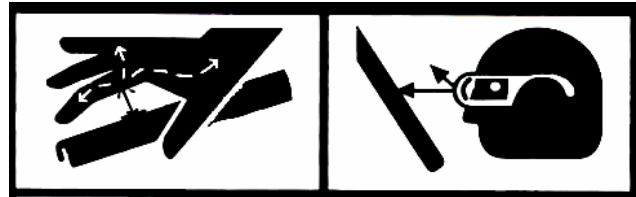

Figure 2.2 Workplace Hazard Area (Hydraulic Drive)

2.4. HYDRAULIC SAFETY

- Always place all tractor hydraulic controls in neutral before disconnecting from tractor or working on hydraulic system.
- Make sure that all components in the hydraulic system are kept in good condition and are clean.
- Replace any worn, cut, abraded, flattened, or crimped hoses.
- Do not attempt any makeshift repairs to the hydraulic fittings or hoses by using tape, clamps, or cements. The hydraulic system operates under extremely high-pressure. Such repairs will fail suddenly and create a hazardous and unsafe condition.
- Wear proper hand and eye protection when searching for a high-pressure hydraulic leak. Use a piece of wood or cardboard as a backstop instead of hands to isolate and identify a leak.
- If injured by a concentrated high-pressure stream of hydraulic fluid, seek medical attention immediately. Serious infection or toxic reaction can develop from hydraulic fluid piercing the skin surface.



2.5. ELECTRIC MOTOR SAFETY

- To prevent serious injury or death, only qualified personnel should service electrical components.
- Keep electrical components in good repair.
- Ground electric motor before using.
- Inspect drive belts before using. Replace if frayed or damaged.

2.6. STORAGE SAFETY

- Store the unit in an area away from human activity.
- Do not permit children to play on or around the stored equipment.
- Fully lower conveyor before storing.

2.7. TIRE SAFETY

- Failure to follow proper procedures when mounting a tire on a wheel or rim can produce an explosion that may result in serious injury or death.
- Do not attempt to mount a tire unless you have the proper equipment and experience to do the job.
- Have a qualified tire dealer or repair service perform required tire maintenance.

- When replacing worn tires, make sure they meet the original tire specifications. Never undersize the replacement tire.
- Do not weld to the tire rim with the tire mounted on the rim. This action may cause an explosion which could result in serious injury or death.
- Inflate tires to the manufacturers's recommended pressure.

2.8. SAFETY DECAL LOCATIONS

- Keep safety decals clean and legible at all times.
- Replace safety decals that are missing or have become illegible. See decal location figures below.
- Replaced parts must display the same decal(s) as the original part.
- Safety decals are available from your distributor, dealer, or factory.

2.8.1. DECAL INSTALLATION

1. Decal area must be clean and dry, with a temperature above 10°C (50°F).
2. Decide on the exact position before you remove the backing paper.
3. Align the decal over the specified area and carefully press the small portion with the exposed sticky backing in place.
4. Slowly peel back the remaining paper and carefully smooth the remaining portion of the decal in place.
5. Small air pockets can be pierced with a pin and smoothed out using the sign backing paper.

2.8.2. DECAL LOCATIONS

Replicas of the safety decals that are attached to the equipment are shown below. Good safety requires that you familiarize yourself with the various safety decals and the areas or particular functions that the decals apply to as well as the safety precautions that must be taken to avoid serious, injury, death, or damage.

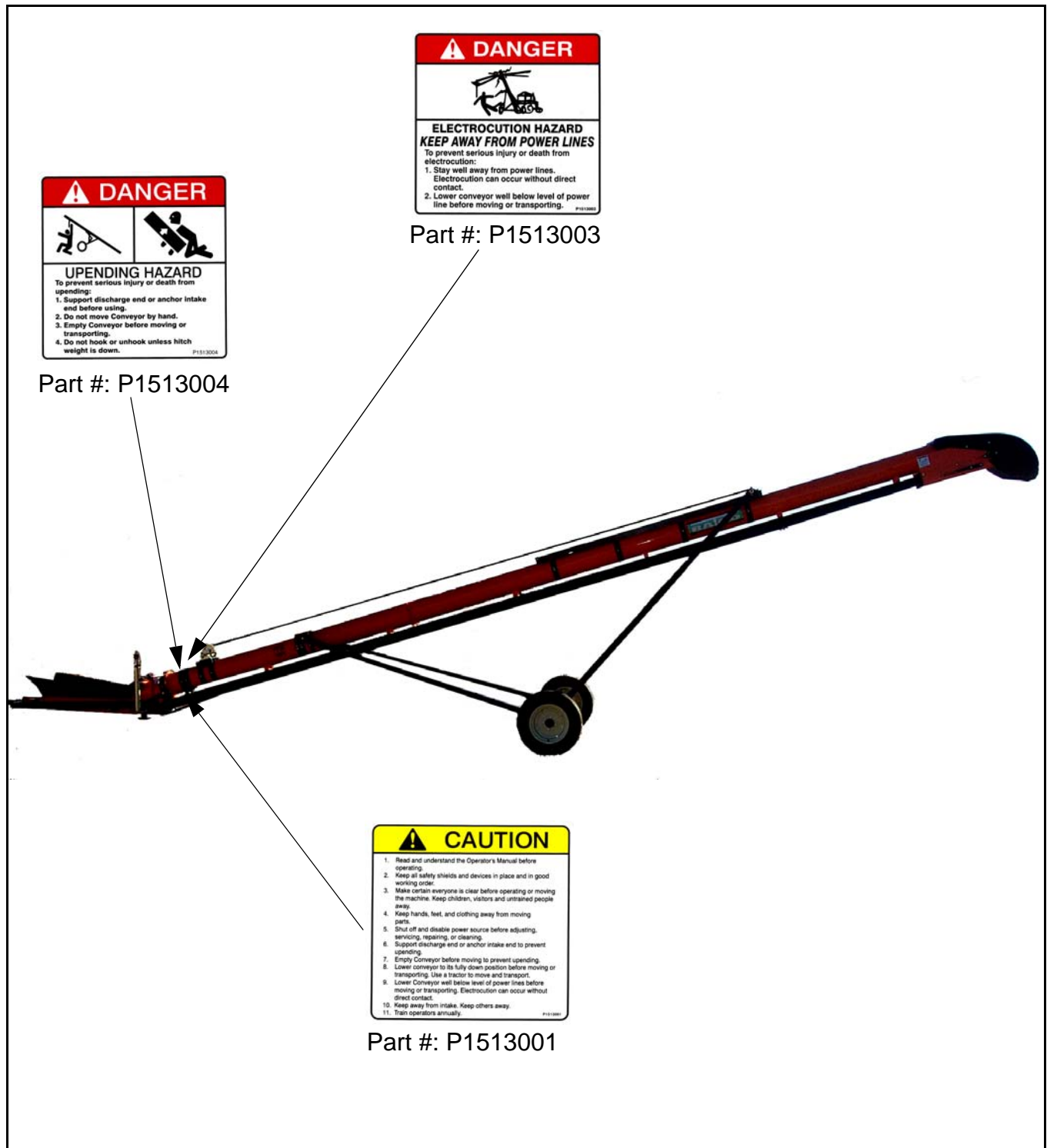

Figure 2.3 Safety Decal Locations (30-55 Conveyors)

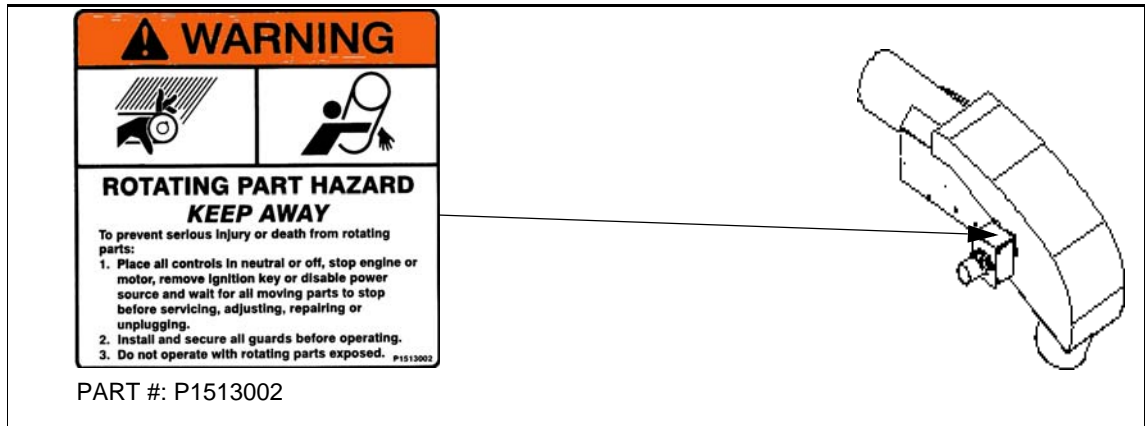

Figure 2.4 Hydraulic Top drive Safety Decal

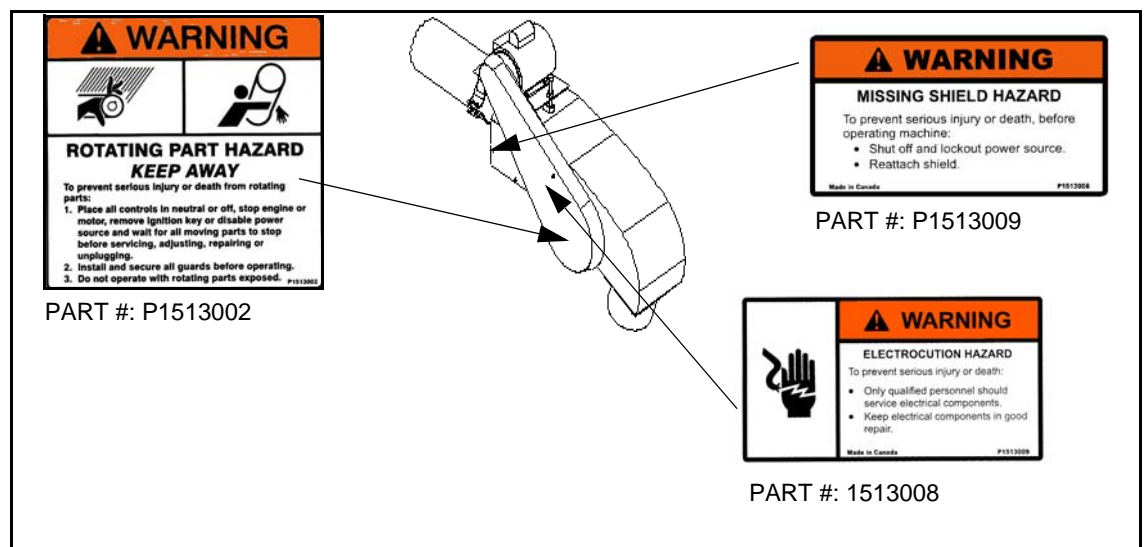

Figure 2.5 Electric Top Drive Safety Decals

3. Components and Controls

Before operating the conveyor, all operators should familiarize themselves with the location and function of the components and controls. See Table 3.1 and Figure 3.1 for details.

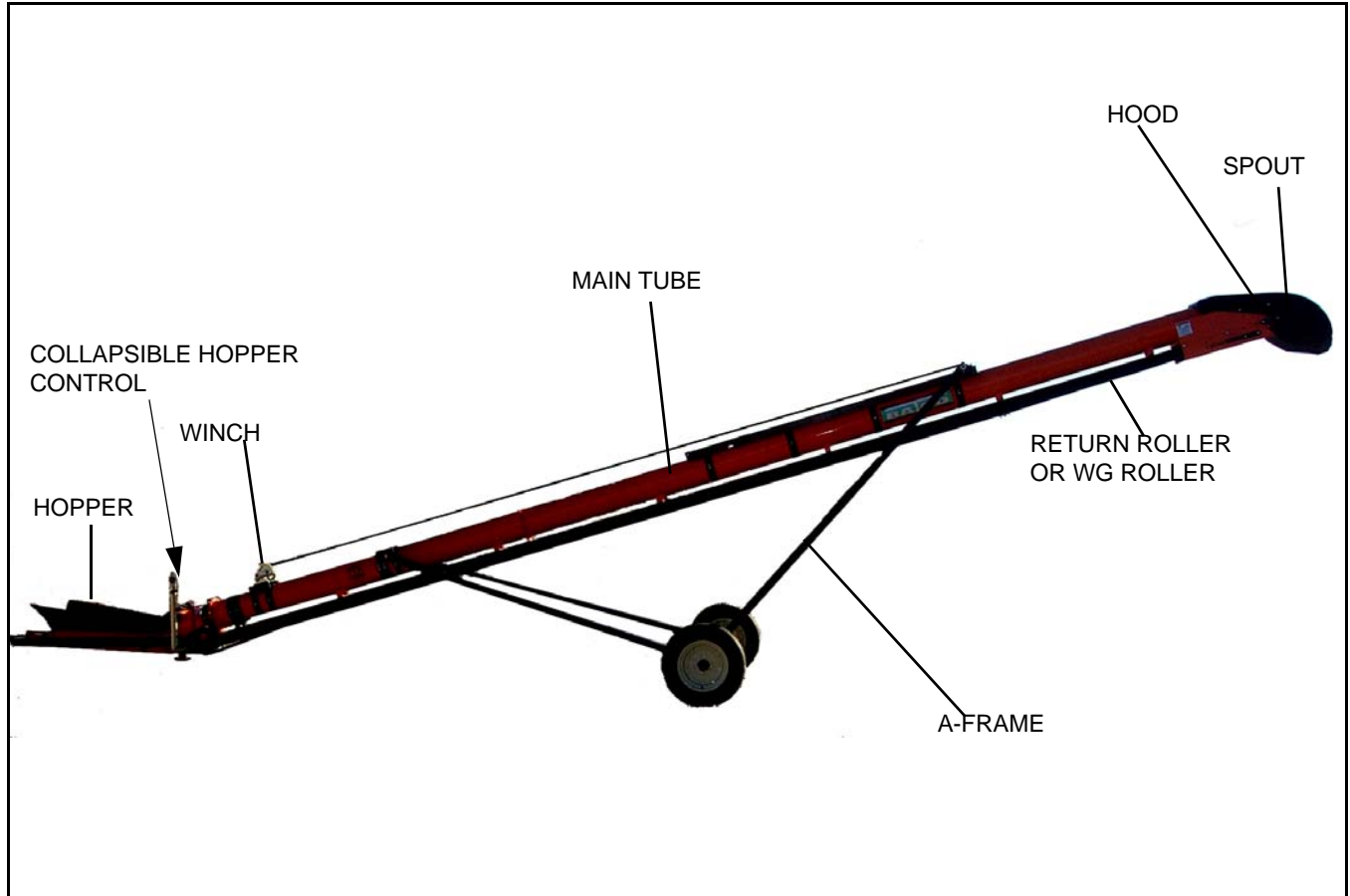

Figure 3.1 Typical Conveyor Components

4. Transport

Warning: Before continuing, please reread the safety information relevant to this section at the beginning of this manual. Failure to follow the safety instructions can result in serious injury, death, or property damage.

NOTICE



It may be necessary to raise the outlet end above the storage facility to provide clearance to raise the intake end.

4.1. PRE-TRANSPORT CHECKLIST

Before transporting conveyor, ensure that:

1. Conveyor is in the fully lowered position.
2. Attach conveyor to towing vehicle with a pin and retainer. Always attach safety chain(s).
- ➔ 3. On **electric motor models**, unplug the power cord, wrap around frame, and secure to prevent dragging.
- ➔ 4. On **hydraulic powered models**, disconnect hydraulic hoses, remove power source, and wrap hose around frame to prevent dragging.

4.2. TRANSPORT PROCEDURE

1. Check with local authorities regarding conveyor transport on public roads. Obey all applicable laws and regulations.
2. Make sure the SMV (slow moving vehicle) emblem and all the lights and reflectors that are required by the local highway and transport authorities are in place, are clean, and can be seen clearly by all overtaking and oncoming traffic.
3. Always use hazard warning flashers on tractor or towing vehicle when transporting unless prohibited by law.
4. Always travel at a safe speed. Use caution when turning corners or meeting traffic.
5. It is not recommended that the machine be transported faster than 20 mph (32 km/h). Table 4.1 references the acceptable transport speed as per the ratio of tractor weight versus conveyor weight. For conveyor weights see Section 10.
6. Use caution when moving conveyors over rolling terrain. In severe dips the discharge end may contact the ground.

Table 4.1 Speed versus Weight Ratio

Road Speed	Weight or fully equipped or loaded implement(s) relative to weight of towing machine
Up to 32 km/h (20 mph)	1 to 1, or less
Up to 16 km/h (10 mph)	2 to 1, or less
Do not tow if	More than 2 - 1

7. Never go across slopes of more than 11°. It is better to go straight up or straight down the slope.

DANGER	
	Stay away from overhead obstructions and power lines when operating and transporting. Electrocutation can occur without direct contact.

5. Placement

Warning: Before continuing, please reread the safety information relevant to this section at the beginning of this manual. Failure to follow the safety instructions can result in serious injury, death, or property damage.

5.1. UNDER HOPPER BOTTOM BINS

BEFORE MOVING CONVEYOR UNDERNEATH HOPPER BIN:

1. Confirm that hopper is centered between the hopper bin vertical legs. This ensures that the operator has adequate clearance.
2. Collapse the cloth hopper until it is positioned under the bin.
3. Move conveyor into place, raise the conveyor spout to desired height.
4. Ensure that the winch is locked or ball valve is shut for hydraulic winch.
5. Make sure that gravel is not jammed against the belt under the hopper.

5.2. FILLING TRUCKS/TANKS

1. Back the machine up to the storage facility while it is in its lowered configuration. Use jack to aid adjustment.
2. Set the park brake on the tractor before dismounting.

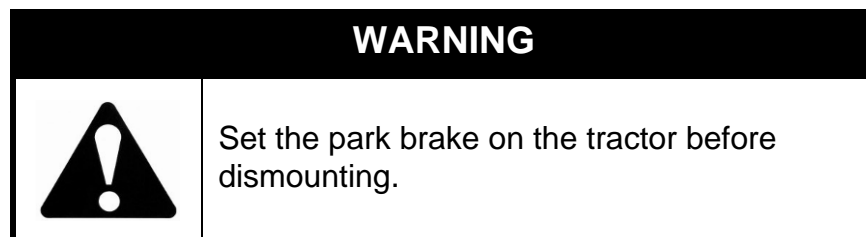

3. When releasing conveyor from the towing vehicle, test the intake end for downward weight.
4. Use the winch to raise the machine so it clears the container.
 - a. Disconnect hydraulic hose and close ball valve.
 - b. Remove the hitch from the machine to prevent interfering with other equipment.
5. Slowly back the machine up until the outlet is under the opening in the storage facility.

6. Unhook the unit from the tractor or towing vehicle and lower hopper to the ground.

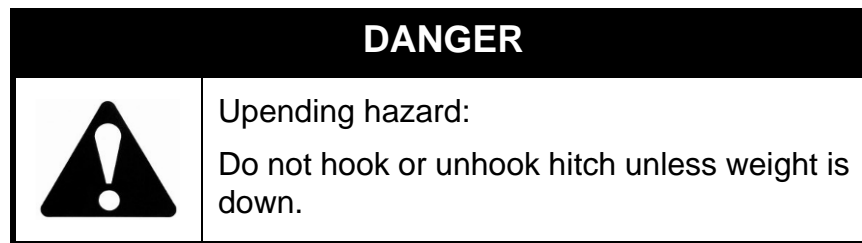

7. Place chocks in the front and back of each wheel.
8. Prior to operating the conveyor, review Section 2.3. and follow all set-up instructions.
9. Check angle of machine and ensure that the machine angle is not too steep an angle to move grain. See Section Section 10.2. on pg. 40 for more help.

6. Operation

Warning: Before continuing, please reread the safety information relevant to this section at the beginning of this manual. Failure to follow the safety instructions can result in serious injury, death, or property damage.

6.1. PRE-OPERATION CHECKLIST

BEFORE OPERATING THE CONVEYOR EACH TIME:

- Service the machine per the schedule outlined in Section 8.1.
- Use only a tractor or electric motor of adequate power to operate the machine. See “Top Drive Field Loader Specifications” on page 39.

Important: *Check winch and cable. There should be at least 3 complete wraps of cable around the winch drum in transport position. Check that cable anchor on winch drum is tight. Inspect cable and replace if frayed or damaged.*

- Check that cable clamps are secure.
- Check that drive (Electric Models) and conveying belts are not frayed or damaged and that they are properly adjusted and aligned. 8.3.5. See “Maintenance” on page 27.
- Ensure wheels are chocked.
- Check that hopper and spout areas are free of obstructions.
- Support discharge end or anchor intake end before using.

6.2. MACHINE BREAK-IN AND OPERATION

Although there are no operational restrictions on the conveyor when used for the first time, it is recommended that the following items be checked:

BEFORE STARTING:

1. Read the conveyor and motor (if so equipped) operation manuals.
2. During the first few minutes of operation, check the conveyor belt alignment to ensure preset alignment does not vary under loaded conditions. See Maintenance section. 8.3.5.

AFTER OPERATING OR TRANSPORTING FOR 1/2 HOUR:

1. Re-torque all the wheel bolts.
2. Re-torque fasteners and hardware.
3. Check the drive and conveyor belt tension and alignment. Tension or align as required. See Maintenance section.

AFTER OPERATING FOR 5 AND 10 HOURS:

1. Re-torque all wheel bolts, fasteners, and hardware.

2. Check the drive and conveyor belt tension and alignment. Tension or align as required.

6.2.1. DRIVE SETUP

HYDRAULIC DRIVE MODEL:

1. Back tractor into position.
2. Chock tractor wheels.
3. Plug hydraulic hoses into tractor couplers. Check flow direction to ensure belt is moving forward.

ELECTRIC MOTOR MODEL:

1. Have a certified electrician provide power to the machine.
2. Provide convenient shutdown switches and comply with local electrical codes.
3. Use a totally enclosed electric motor when conveying in extremely dusty conditions. Ensure electric motor is properly grounded.

6.2.2. STARTING CONVEYOR

WARNING	
	Anchoring and/or support of the conveyor during operation is necessary. When emptying the conveyor, the weight balance transfers to the upper end of the machine, which can cause upending.

HYDRAULIC DRIVE INSTRUCTIONS

1. Place all controls in neutral.
2. Start tractor and run at low idle.
3. Engage hydraulic control lever and increase engine speed to desired speed.

Note: *The correct operation of hydraulic systems is directly linked to the pump's ability to supply the correct oil flow and pressure. If you cannot obtain the correct belt speed, check with the dealer to ensure the power unit is delivering the correct oil volume and pressure.*

1. Turn the electric motor ON..

CAUTION	
	Conveyor should not be left in a raised position for extended periods of time. Fully lower conveyor to prevent the risk of damage or personal injury.

6.2.3. CONVEYOR SHUTDOWN

HYDRAULIC DRIVE MODELS:

1. Run until the belting is empty.
2. Reduce engine speed to low idle.
3. Place hydraulic control lever in neutral.
4. Shut off engine and remove ignition key.

ELECTRIC MOTOR MODELS:

1. Run until the belting is empty.
2. Turn off motor and lock out power source.

6.2.4. EMERGENCY SHUTDOWN

Although it is recommended that the tube be emptied before stopping, in an emergency situation, stop or shut down the power source immediately.

Important: *Lock out all power and ensure the machine components come to a stop before inspecting.*

Correct the emergency before resuming work.

6.2.5. RE-STARTING (FULL TUBE)

When the machine is shut down inadvertently or for an emergency, the tube will still be filled with material.

➔ **Electric Drives:** It may be necessary to tighten the drive belts slightly to handle the heavier than normal loads. See Section 8.3.3.

6.2.6. CONVEYOR OPERATING ANGLES

The conveyor lift can set the tube angle at any position between 12° and 30° when operating. Because the belt does not have roll back barriers, the material will roll back if the angle is too steep. Do not position the conveyor at an angle steeper than the angle of repose of the material to be moved.

See Section 10.2. for help on determining these angles.

Note: *The lower the angle, the greater the capacity.*

6.2.7. BELT SPEED

The best results are obtained when the input drives are set to provide a belt speed of 500 to 600 ft/min on the 1300 and 1500 series, and 600 to 650 on the 1800 and 2000 series.

Count the number of belt revolutions per minute to determine belt speed. Approximate belt length is double the length of your machine plus 3'. See Section 10.1. on page 39 for belt lengths.

Note: Use the connector splice as a reference when counting belt revolutions.

Contact your dealer or the factory for the appropriate drive components to obtain the recommended belt speed.

6.2.8. OPERATING TIPS

- Direct the flow of material into the input hopper in the direction of the belt for the best capacity.
- Attempting to move material at too steep an angle can result in excessive slide back and poor capacity.
- Always listen for any unusual sounds or noises. If any are heard, stop the machine and determine the source. Correct the problem before resuming work.
- ➔ • An optional hydraulic lift is available for the machine. Always close the hydraulic safety ball valve when the machine is positioned.
- Do not run the machine for long periods of time without material on the belt- ing. It increases belt wear.
- Do not support outlet end directly on the storage facility. Tie down the intake (hopper) or weigh it down to prevent upending.
- To achieve maximum capacity, feed material onto belt until material tube clearance is 1/2"; do not flood feed hopper.
- Load materials in the loading zone indicated in Figure 6.1.

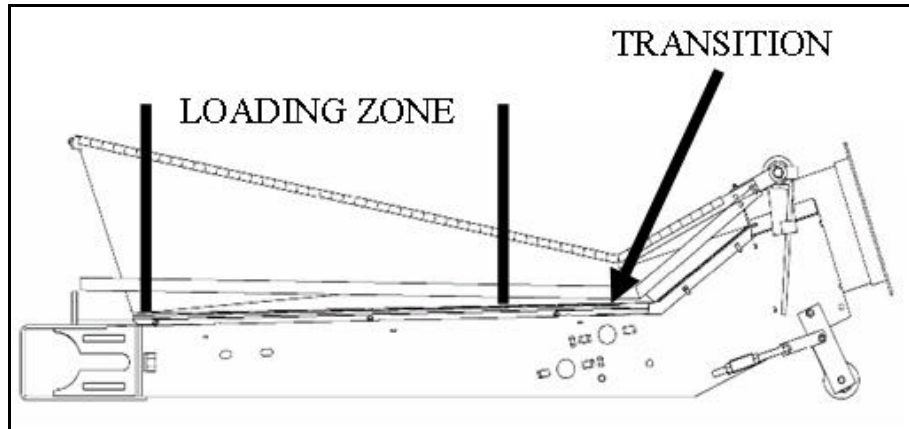

Figure 6.1 Field Loader Hopper Loading Zone

7. Storage

WARNING

Before continuing, please reread the safety information relevant to this section at the beginning of this manual. Failure to follow the safety instructions can result in serious injury, death, or property damage.

To PROTECT THE CONVEYOR IN STORAGE:

1. Lower the conveyor to its lowest position for storage.
2. Select an area that is dry, level, and free of debris.
3. Remove all residual material from the conveyor.
4. Stop machine so that the belt lacing is inside the tube. This protects the lacing from weathering.
5. Wash the entire machine thoroughly using a water hose or pressure washer to remove all dirt, mud, debris, or residue.
6. Inspect all hydraulic hoses (if equipped), fittings, lines, couplers, and valves. Tighten any loose fittings. Replace any fitting or hose if damaged.
7. Touch up all paint nicks and scratches to prevent rusting.
8. If machine is not equipped with belt weather guards, position it in such a way as to limit wind exposure to the belt.
9. Place a block under the jack to ensure it will not freeze to the ground in the winter.

To prepare the conveyor for use after storage, perform general maintenance. See Section 8.3. for further details.

8. Maintenance

Warning: Before continuing, please reread the safety information relevant to this section at the beginning of this manual. Failure to follow the safety instructions can result in serious injury, death, or property damage.

8.1. MAINTENANCE SCHEDULE

8.1.1. INITIAL START-UP SERVICING

Since the belt alignment is preset to run true under a condition of no load, it is important to check alignment and make adjustments if required during the initial few minutes of loaded operation. To adjust alignment, see Section 8.3.5. Conveyor Belt Alignment on page 31.

8.1.2. 8 HOURS OR DAILY

ALL MODELS

- Check the conveyor belt tension and alignment (See Section 8.3.3.).

ELECTRIC DRIVE MODELS

- Check drive belt tension and alignment.

HYDRAULIC DRIVE MODELS

- Check hoses for wear.

8.1.3. 40 HOURS OR WEEKLY

- Check the conveying belt tension and alignment (See Section 8.3.3.).
- Check condition of hopper flashing. Be sure it seals the hopper and prevents grain leakage.
- If equipped, look for hydraulic leaks and repair if required.

8.1.4. 200 HOURS OR ANNUALLY

- Check tire pressure and add air if required. Inflation pressure details can be found on the tire itself.
- Check roller bearings for wear. Any rollers making noise, getting hot while running, or that have play should be replaced.
- Repack wheel bearings.
- Wash machine.
- Inspect roller lagging to see if it is showing signs of wear.

- Check belt lacing. If any clips are worn through, replace all lacing.
- Check hopper flashing for wear and replace any that are worn. Worn flashing will cause hopper leakage.

NOTICE

Operating the conveyor with a damaged roller will result in a damaged conveyor belt.

8.2. MAINTENANCE CHECKLIST

Use the maintenance checklist provided to keep a record of all scheduled maintenance.

See Lubrication and Maintenance sections for details of service. Photocopy this page to continue record keeping.

Note: All options may not apply to your machine.

✓ Check CL Clean L Lubricate C Change R Re pack

8 Hours/Daily	Day	1	2	3	4	5	6	7	8	9	10	11	12	13	14	15	16	17	18	19	20	21	22	
✓ Conveyor Belt Tracking																								
✓ Fuel & Oil Level(s)																								
8 Hours/Daily	Day	23	24	25	26	27	28	29	30	31	32	33	34	35	36	37	38	39	40	41	42	43	44	
✓ Conveyor Belt Tracking																								
✓ Fuel & Oil Level(s)																								
8 Hours/Daily	Day	45	46	47	48	49	50	51	52	53	54	55	56	57	58	59	60	61	62	63	64	65	66	
✓ Conveyor Belt Tracking																								
✓ Fuel & Oil Level(s)																								
8 Hours/Daily	Day	67	68	69	70	71	72	73	74	75	76	77	78	79	80	81	82	83	84	85	86	87	88	
✓ Conveyor Belt Tracking--																								
✓ Fuel & Oil Level(s)																								
40 Hours/Weekly	Week	1	2	3	4	5	6	7	8	9	10	11	12	13	14	15	16	17	18	19	20	21	22	
✓ Belt Tension & Alignment																								
✓ Conveyor Belt Tracking																								
✓ Hopper Flashing Condition																								
✓ Check for Hydraulic Leaks																								
Electric Drive Models																								
✓ Drive Belt Tens. & Align.																								
200 hours / Annually		Year 1	Year 2	Year 3		Year 1	Year 2	Year 3																
✓ Tube Straightness					✓ Belt Lacing																			
✓ Roller Bearings					✓ Hopper Flashing																			
R Wheel Bearings					Hydraulic Drive Models																			
CL Machine					L Roller Chain-Input Coupler																			
✓ Roller Lagging																								
✓ Check Tire Pressure																								

8.3. SERVICE & MAINTENANCE PROCEDURES

By following a careful service and maintenance program for your machine, you will enjoy many years of trouble-free service.

8.3.1. FLUIDS AND LUBRICANTS

GREASE:

- Use SAE multi-purpose high temperature grease with extreme pressure (EP) performance. SAE multi-purpose lithium based grease is also acceptable.

STORING LUBRICANTS:

- Your machine can operate at top efficiency only if clean lubricants are used. Use clean containers to handle all lubricants. Store them in an area protected from dust, moisture, and other contaminants.

8.3.2. GREASING

Note: *Most original equipment bearings used by Batco are sealed units and will not accept grease.*

1. Wipe grease fitting with a clean cloth before greasing to avoid injecting dirt and grit.
2. Replace and repair broken fittings immediately.
3. If fittings will not take grease, remove and clean thoroughly. Also clean lubricant passageway. Replace fitting if necessary.

8.3.3. CONVEYOR BELT TENSION AND ALIGNMENT

Adjusting your conveyor belt for proper tension helps to ensure trouble-free operation and long belt life. A conveyor belt only needs to be tight enough to not slip on the drive roller. If the belt is too loose, it will slip on the drive roller making a noticeable sound and slowing the belt down. To correct belt slippage and set proper tension in the belt, follow the steps in the corresponding section below.

Important: *If belt is slipping and adjustment bolts are fully tightened, then belt must be shortened. See Section 8.3.7.*

Belt should not be easy to pull from the hopper transition sides, otherwise the belt will require tensioning.

WARNING



Ensure ignition key is removed, or lock out power source before adjusting or servicing conveyor.

NOTICE

Do not operate conveyor if belt is slipping. Stop conveyor and tighten belt. Failure to do so will damage the belt and may void the warranty.

Important: *Some belts may have uneven edges, appearing misaligned. Wait until the belt makes a complete revolution before adjusting rollers.*

8.3.4. BELT TENSION INSTRUCTIONS

WARNING



Before tensioning belt, remove ignition key and lock out power.

After tensioning belt, replace guards if removed.

PINCH TOP DRIVE

1. Loosen bearing bolts and jam nut (if included) at tightener roller (see Figure 8.2).
2. Check to ensure pinch roller is moveable.
3. Tighten tightener bolts equally, use tape to verify. Belt should deflect 1-2" when pushed down with a 5 lb force, or be difficult to pull from sides of hopper transition.
4. Tighten bearing bolts and jam nut (if included).
5. Check belt tension by running conveyor for one minute. If belt is not slipping, then proceed to next step; otherwise repeat from step 1.
6. If belt is not slipping, but now running to one side, the tensioned roller needs to be re-aligned. See "Conveyor Belt Alignment" on page 31.

NOTICE

Take-up springs must not be tensioned more than the pinch springs or slippage may result.

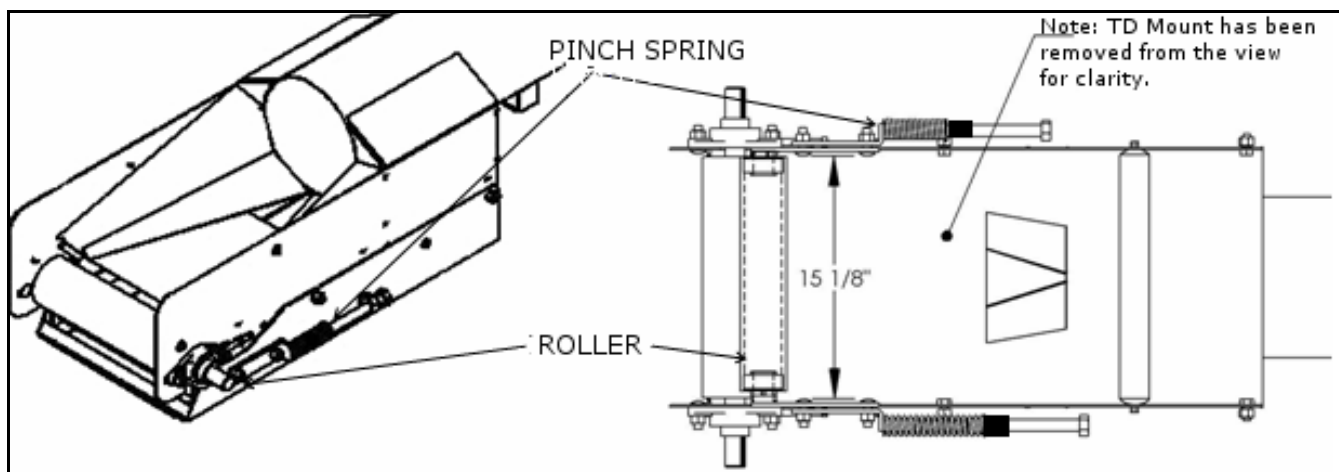

Figure 8.1 Pinch Top Drive

8.3.5. CONVEYOR BELT ALIGNMENT

If your belt is tracking to one side, use the instructions below and follow the steps listed to center it. Follow the steps in the appropriate section(s) in order. If you are unsure where the problem is, start at the beginning of this section and work your way to the end. Skip sections that do not apply. The process can be lengthy but will help ensure trouble-free operation and long belt life.

Important: *Ensure that conveyor is empty of all product before adjusting belt alignment.*

WARNING



Before aligning belt, remove ignition key and lock out power.

After aligning belt, replace guards if removed.

HOPPER ROLLER

1. Loosen bearing bolts and jam nut (if equipped).
2. Rotate adjustment bolt 1/2 turn on the side the belt is running toward.
3. Restart conveyor and run empty for one minute.
4. Stop conveyor, remove ignition key or lock out power source.
5. If belt has centered, then move to next step below; otherwise, repeat from step 2.
6. Tighten bearing bolts and jam nut (if equipped).

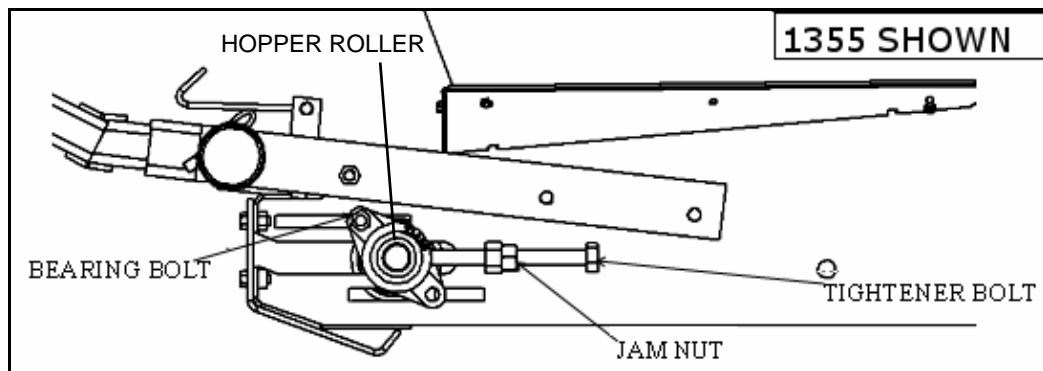

Figure 8.2 Hopper Roller

TRANSITION ROLLERS

Note: *The top transition roller should be the only one requiring adjustment. Only in extreme cases does the bottom transition roller require adjustment (Figure 8.3).*

1. Loosen bearing bolts and jam nut (if equipped).
2. Rotate adjustment bolt 1/2 turn on the side the belt is running towards.
3. Restart conveyor and run empty for 1 minute.
4. Stop conveyor, remove ignition key or lock out power source.
5. If belt centered, then move to next step below; otherwise, repeat from step 2.
6. Tighten bearing bolts and jam nut (if required).

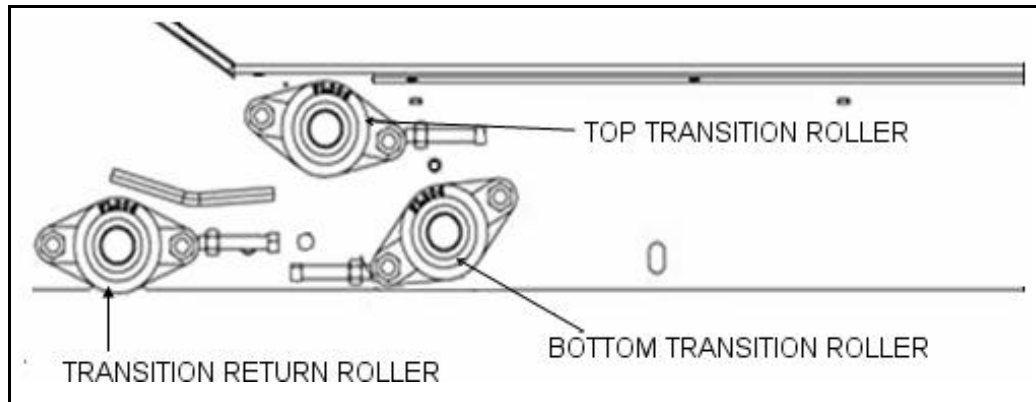

Figure 8.3 Field Loader Transition Rollers

HEX ROLLERS / WEATHER GUARDS

1. Start at hopper or last adjusted roller and check that belt is centered on each belt return bracket.
2. If belt is not centered, adjust bracket toward hopper slightly on side belt is tracking toward.
3. Adjust wear blocks if unit has weather protectors (see Figure 8.4).

Note: *Wear blocks are located on every second weather protector bracket.*

4. Restart conveyor and run empty for 1 minute.
5. Stop conveyor, remove ignition key or lock out power source.
6. If belt has not centered repeat from step 2.

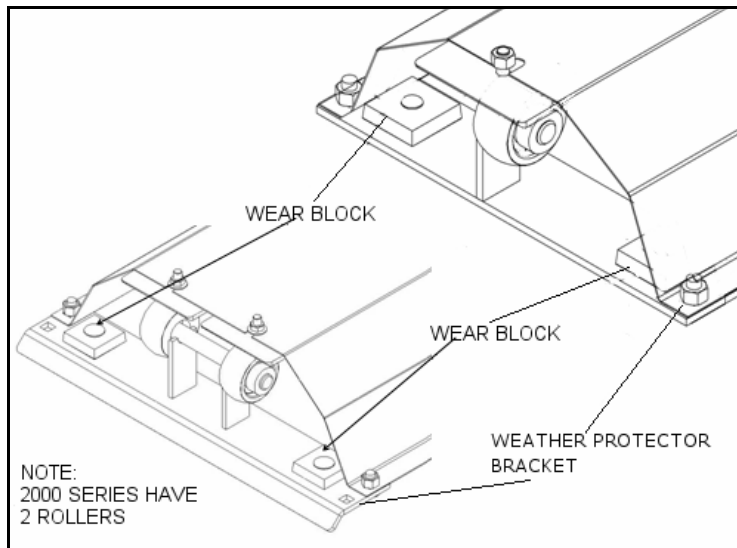

Figure 8.4 Weather Guard Guide Block

8.3.6. CONVEYOR BELT REPLACEMENT

1. Rotate the belting until the lacing is by the hopper or easily accessible.
2. Move the tension roller to its loosest position.
3. Pull all the slack to the lacing area.
4. Remove the lacing pin (see Figure 8.6).
5. Attach one end of the replacement belt to the belt end being removed, closest to the hopper.

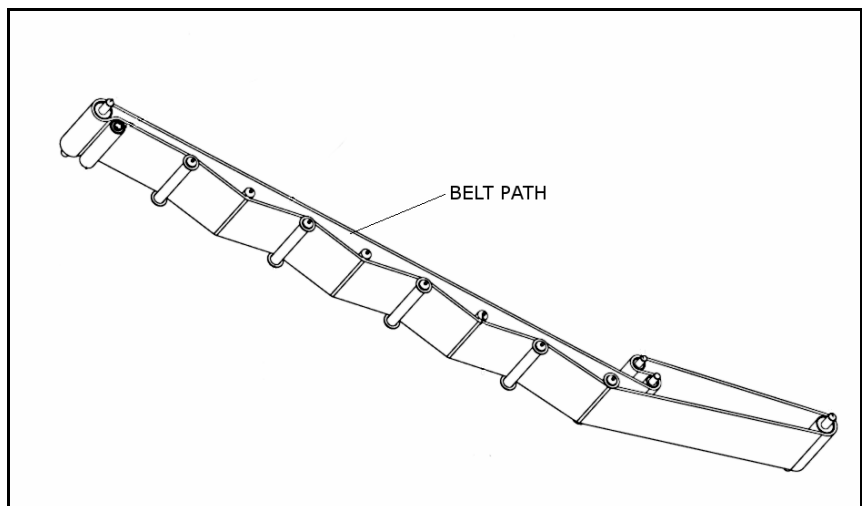

Figure 8.5 Belt Path

Important: *Ensure that the belt is installed as shown in Figure 8.6. Note the direction of belt travel and square and trimmed edge positions.*

6. Pull the old belt out and the new belt will be threaded into place.
7. Disconnect the old belt.
8. Reattach conveyor belt ends together. If required, use a ratchet strap clamped to both ends of belt to cinch belting ends together.
9. Install lacing pin and crimp retainer clips onto each end of the lacing pin.
10. Remove ratchet strap and tighten conveyor belt. (See Section 8.3.3.)
11. Check and set belting alignment. (See Section 8.3.3. and 8.3.5.)

12. Engage conveyor drive. Allow to run for 30 seconds, then shut down conveyor and inspect lacing.

8.3.7. BELT RELACING

1. Rotate the belting until the lacing is by the hopper or easily accessible.
2. Loosen conveyor belt and remove lacing retainer clip and pin.
3. Using a square and sharp knife, cut lacing off right behind the lacing clips. Cut belt **MUST** have a square end.
4. Use knife to cut Chevron pattern off 1" back from end of belt. This ensures that the lacing is centered and fully seated on the belt.
5. Use lacing tool to install new lacing clips. Lacing clips are one clip shorter than belt width. For example: the lacing for a 15" wide belt is 14 clips. Center lacing on belt and install lacing as per instructions on lacing tool.
6. Reattach conveyor belt ends together. If required, use a ratchet strap clamped to both ends of belt to cinch belting ends together.
7. Install lacing pin and crimp retainer clips onto each end of the lacing.
8. Remove ratchet strap and tighten conveyor belt (see Section 8.3.3.).
9. Check and set belting alignment (see Section 8.3.3.8.3.5.).
10. Clear area of all bystanders and engage conveyor drive. Allow to run for 30 seconds, then shut down conveyor and inspect lacing.

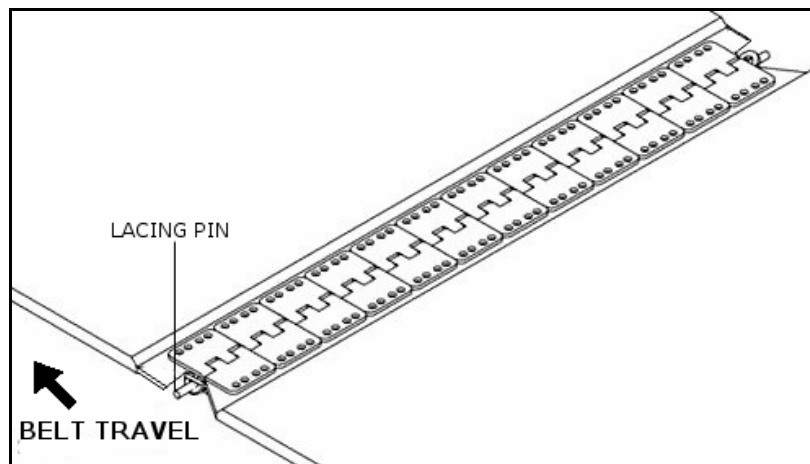



Figure 8.6 Belt Lacing Pin

8.3.8. DRIVE BELT TENSION & ALIGNMENT (ELECTRIC DRIVE)

Power to the conveyor is transmitted through a set of v-belts. The drive system must be maintained at the proper belt tension and pulley alignment to obtain desired performance and life. When maintaining the belt drive system follow the appropriate sections below.

WARNING	
	Before working on drive belt: Electric Drives: Turn motor off and unplug power cord or turn off power at master panel.

BELT TENSION

1. Push on the center of the belt span with a force of approximately 5 lb.
2. The belts will deflect approximately 1/4" to 1/2" when properly tensioned.
3. Move the motor base to set drive belt tension.
4. Close and secure guards.

BELT ALIGNMENT

1. Lay a straight edge across the pulley faces to check the alignment.
2. Use the pulley hub to move the pulley to the required position for alignment.
3. Tighten hub bolts to secure pulley on shaft.
4. Check belt tension.
5. Close and secure guards.

BELT REPLACEMENT

1. Move motor base to its loosest position.
2. Remove old belts and replace with new one.
3. Check pulley alignment. Adjust if required.
4. Close and secure guards.

9. Troubleshooting

The Batco Grain Conveyor is a simple and reliable system that requires minimal maintenance. In the following section, we have listed many of the problems, causes, and solutions to the problems that you may encounter.

If you encounter a problem that is difficult to solve even after having read through this troubleshooting section, please call your local Batco dealer or distributor. Before you call, please have this operation manual and the serial number from your machine ready.

Overall

Problem	Cause	Solution
Low conveying capacity.	• conveyor angle is too high	• re-position with lower tube angle (see Section 10.2.)
	• incorrect belt speed	• verify and adjust belt speed to appropriate speed (see Section 8.3.3.)
	• conveyor belt slipping	• see Section 8.3.3.
	• drive belts slipping	• see Section 8.3.3.
Low capacity for some grains.	• smaller and smoother grains will slide at shallower angles	• see Section 6.2.8.

Belt

Problem	Cause	Solution
Belt slipping.	• conveying belt loose	• tighten and align belt (see Section 8.3.3.8.3.5.)
	• drive roller lagging worn or damaged	• replace drive roller lagging
	• drive belts loose	• tighten and align (see Section 8.3.3.8.3.5.)
	• belt frozen to tube from operating in high humidity in cold conditions	• remove conveyor from area of high humidity and warm belt to de-ice
Excessive belt edge fraying.	• belt not aligned	• align and tension belt (see Section 8.3.3.8.3.5.)
Belt loose.	• belt stretches over time	• re-tension belt (see Section 8.3.3.)
		• can also be caused by oily grain/product
		• if belt tightener on s-drive is fully engaged, you may need to shorten belt (see Section 8.3.3.)

Hopper

Problem	Cause	Solution
Grain leaking from conveyor hopper.	• belt not tracked (centered)	• track belt (see Section 8.3.3. 8.3.5.)
	• flashing installed incorrectly or worn	• inspect flashing for wear and replace if required
	• hopper cloth worn or damaged	• replace damaged hopper cloth
	• transition filler rings are worn or need replacement	• adjust transition filler rings; replace if worn
Hopper cloth collapsing under grain.	• misaligned or broken spring(s)	• check spring installation and repair as required
	• pivot shafts improperly installed	• on some machines, switching pivot shafts left to right will increase hopper tension

Drive

Problem	Look For	Solution
Drive making noise.	• slipping belt	• see Section 8.3.3. 8.3.5.
	• hot shaft, pulley or bearing	• overheated components indicate a failed bearing that must be repaired
	• broken drive roller	• replace damaged component

Spout

Problem	Cause	Solution
Grain leaking from conveyor spout between belt and tube.	• belt not tracked (centered)	• track belt (see 8.3.3.8.3.5.)
Grain leaking from conveyor spout between hood and belt.	• belt speed is too fast, hood plugging	• decrease belt speed or feed rate

Frame

Problem	Cause	Solution
Conveyor will not stay elevated	• faulty winch	• lower machine to transport position and repair or replace winch
	• faulty cable	• lower machine to transport position and repair or replace cable
Conveyor makes noise while lifting.	• frame parts loose and move while lifting	• replace damaged components and re-tension frame fasteners

Brackets

Problem	Cause	Solution
U-clamps sliding on tube.	• clamp not properly crimped to tube	• contact your local dealer for correct positioning

10. Appendix

10.1. TOP DRIVE FIELD LOADER SPECIFICATIONS

NOTE: ALL ANGLES AND MEASUREMENTS SHOWN ARE MACHINE LIMITS. THE MAX OPERATION ANGLE DEPENDS ON THE PRODUCT BEING CONVEYED, USUALLY LESS THAN 30°.

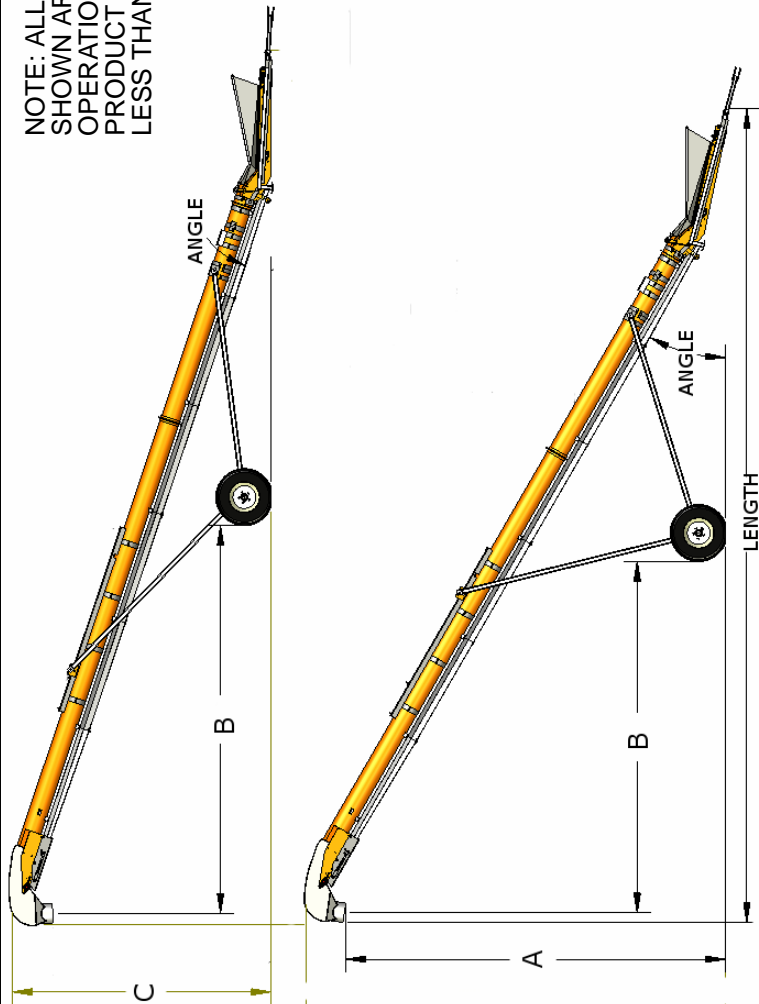

Table 10.1 Top Drive Field Loaders

Model #	UP - OPERATION			DOWN - TRANSPORT			Overall Width	Length	PTO (HP)	Electric (HP)	Gas (HP)	Hyd (HP) (Cu. in.)
	Belt Length	Total Weight	Angle	C	B	Angle						
1335 ELEC	76' 4"	1624	30.0	11.9	14.6	19.0	7.5	35.0	n/a	7.5	n/a	6.2 (2000)
1335 HYD	76' 4"	1684	30.0	11.3	17.0	19.0	7.5	35.0	n/a	7.5	n/a	6.2 (2000)
1345 ELEC	96' 4"	2095	30.0	13.2	19.5	15.0	7.5	45.0	n/a	7.5	n/a	6.2 (2000)
1345 HYD	96' 4"	2155	29.0	10.5	23.3	13.0	7.5	45.0	n/a	7.5	n/a	6.2 (2000)
1535 ELEC	80' 5"	1766	30.0	11.5	17.0	18.0	7.5	35.0	n/a	10.0	n/a	6.2 (2000)
1535 HYD	80' 5"	1826	30.0	12.5	19.2	20.0	7.5	35.0	n/a	10.0	n/a	6.2 (2000)
1540 ELEC	80' 8"	1913	30.0	13.4	17.1	19.0	7.5	40.0	n/a	10.0	n/a	6.2 (2000)
1545 ELEC	100' 5"	2349	30.0	13.2	22.0	16.0	7.5	45.0	n/a	10.0	n/a	6.2 (2000)
1545 HYD	100' 5"	2409	30.0	11.5	24.6	14.0	7.5	45.0	n/a	10.0	n/a	6.2 (2000)
1835 TDFL	82' 11"	2536	31.0	13.7	15.3	22.0	7.5	35.0	n/a	10.0	n/a	6.2 (2000)

10.2. CONVEYOR PRODUCT CHART

The following table indicates the maximum angle a conveyor can move grain.

To roughly determine conveyor angle, use angle guide on right. Stand the manual (vertically) on conveyor s-drive or tube and hold a string with a weight attached to end against the top of this page. Weighted end of string will fall between degree lines, and from this the approximate angle of the conveyor can be determined.

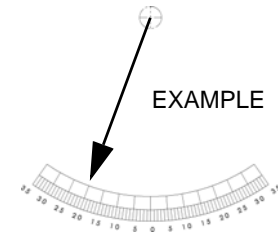

EXAMPLE

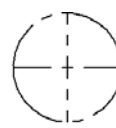

Other Materials	Maximum Conveyor Operating Angle (degrees)
Sawdust	38
Coal	27-45
Wood Chips	>45

Grain	Maximum Conveyor Operating Angle (degrees)
Flax	24
Lentils	29
Mustard	26
Oats	28
Peas	30
Rice	36
Rye	25
Soybeans	28
Sunflower	22
Triticale	23
Wheat	26

Grain	Maximum Conveyor Operating Angle (degrees)
Alfalfa Pellets	34
Barley	25
Canary Seed	26
Canola	25
Chickpeas	30
Corn	26
Shelled Corn (Dry)	25
Shelled Corn (Wet)	28
Cotton Seed	30-45
Durum	25

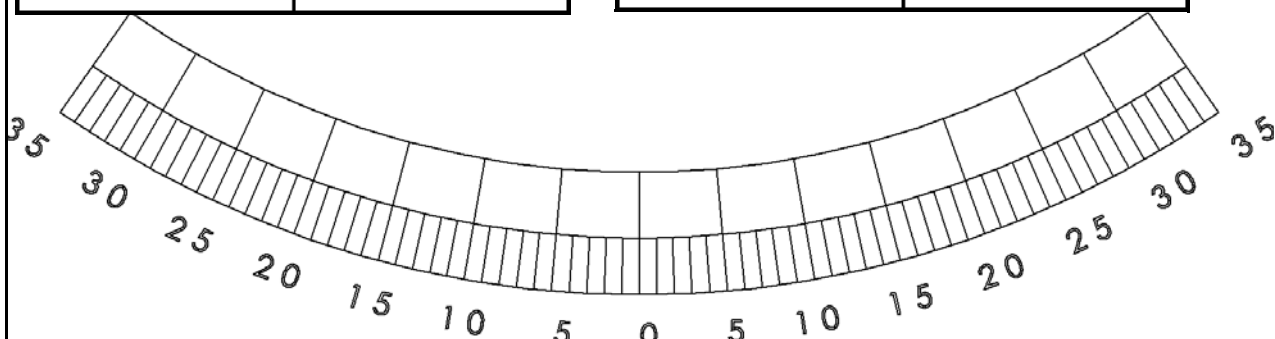

NEW EQUIPMENT WARRANTY

Batco Manufacturing Ltd. will warrant each new conveyor to be free from factory defects in material and workmanship under normal use and service when set up and operated in accordance with factory instructions.

Commercial applications will reduce the warranty period to 90 days from the original date of delivery.

This warranty will apply under the following conditions:

- The warranty will be limited to one year from the date of purchase.
- A “Warranty Registration Form” and “Inspection Report” must be filled out and returned to Batco Manufacturing Ltd. at the time of sale in order to qualify for replacement of defective parts.
- The warranty is void on any unit that has been tampered with or has been subject to misuse, negligence, or accident.
- The warranty is limited to the supplying of replacement parts in exchange for parts defective due to material or factory workmanship.
- The warranty covers material only, unless expenditures are pre-authorized by Batco Manufacturing Ltd. in writing.
- A reasonable allowance may be charged to cover labor for replacement of damaged parts at the discretion of the Batco Warranty Department.
- Normal wear and service items such as belts, hoses, flashing, etc., will only be considered warranty at the discretion of the Batco Warranty Department.

All warranty repairs must be performed at an authorized Batco dealership in order to receive credit.

Returned parts must be sent to the factory freight prepaid in order to qualify for warranty replacement, and will be returned freight collect.

Please direct all claims to the attention of the Warranty Department at Batco Manufacturing Ltd. (306-773-7779)



Batco Manufacturing is a Division of Ag Growth Industries LP

Part of the Ag Growth International Inc. Group

2165 North Service Road West

Swift Current, Saskatchewan CANADA S9H 5K9

PHONE: (306) 773-7779

FAX: (306) 778-2524

EMAIL: info@batcomfg.com

WEB: www.batcomfg.com

© Ag Growth Industries Limited Partnership 2009

Printed in Canada